

Eaton 91PS/93PS UPS

8-10 kW

User's and installation guide



Powering Business Worldwide

Copyright © 2023 Eaton Corporation plc. All rights reserved.

This manual contains important instructions that you should follow during installation and maintenance of the UPS and batteries. Please read all instructions before operating the equipment and save this manual for future reference.

This is a product for commercial and industrial application in the second environment. Installation restrictions or additional measures may be needed to prevent disturbances. The contents of this manual are the copyright of the publisher and may not be reproduced (even extracts) without the written approval of Eaton Corporation. Every care has been taken to ensure the accuracy of the information contained in this manual, but no liability can be accepted for any errors or omission. The right to make design modifications is reserved.

Unauthorized copying and lending are prohibited.

Eaton Electric Oy

Address: Riistakuja 1
FI-01740 Vantaa
FINLAND

Internet: www.eaton.eu

Approvals and version history

REVISION	DATE	DESCRIPTION OF CHANGE	APPROVED BY
001	May 2017	First issue	Otto Asunmaa
002	July 2017	Second issue	Otto Asunmaa
003	May 2018	91PS information added	Otto Asunmaa
004	June 2019	Battery sidecar option added	Otto Asunmaa
005	October 2023	Minor updates due to EU-directive change	Stephan Koehler

These are the original instructions.

Contents

1	How to read this manual	6
1.1	Safety-related signs	6
1.2	Symbols and abbreviations	6
1.3	Conventions used in this document	8
1.4	Glossary	8
2	Safety instructions	10
2.1	General safety instructions	10
2.2	Audience	12
2.3	CE marking	12
2.4	User precautions	12
2.5	Environment	13
2.6	Symbols on the UPS and accessories	13
2.7	For more information	14
3	Introduction to Eaton 91PS/93PS 8-10 kW UPS	15
3.1	About the Eaton UPS	15
3.2	Looking inside the UPS system	16
3.3	UPS operating modes	17
3.3.1	Normal operating modes	17
3.3.1.1	Double conversion mode	17
3.3.1.2	Energy Saver System mode	19
3.3.2	Stored energy and battery mode	20
3.3.3	Bypass mode	21
3.3.4	Maintenance Bypass Switch	22
3.4	UPS features	23
3.4.1	Advanced Battery Management	23
3.4.2	Powerware Hot Sync	23
3.4.3	Power Conditioner	23
3.4.4	Frequency Converter	24
3.5	Software and connectivity features	24
3.5.1	User interface	24
3.5.2	Power Management Software	24
3.6	Options and accessories	24
3.6.1	External Maintenance Bypass Switch Panel (accessory)	24
3.7	Battery system	25
3.8	Basic system configurations	25
4	UPS installation plan and unpacking	26
4.1	To install the UPS	26
4.2	Create an installation plan	26
4.3	Installation checklist	26
4.4	Site preparations	27
4.4.1	Environmental considerations	27
4.4.2	Installation considerations	28
4.4.3	UPS system power wiring preparations	31

4.5	Unpack and unload the UPS	38
5	UPS system installation	41
5.1	Introduction to UPS system installation	41
5.2	Steps to install the UPS	41
5.3	91PS/93PS 8-10 kW UPS Single feed installation.	44
5.4	91PS input system field configuration	44
5.5	Battery system installation	46
5.5.1	Battery trip wiring	47
5.6	Installing additional batteries and battery power cabling	47
5.7	Installing a remote EPO switch	48
5.8	Installing interface connections	49
5.8.1	Installing customer input signals interface.	49
5.8.2	Battery breaker wiring interface	50
5.8.3	Relay output interface connections	50
5.8.4	Industrial Relay Card interface connections	50
5.8.5	Minislot interface connections	51
5.8.6	Installing signal interface connections in a parallel system	51
5.9	Wiring parallel 91PS/93PS UPS systems.	51
5.9.1	Power wiring overview	52
5.9.2	Control signals overview	53
5.9.3	Installing bypass control wiring	54
5.10	UPS system interface wiring preparation	55
6	Communication interfaces	57
6.1	Introduction to communication interfaces.	57
6.2	MiniSlot cards	58
6.3	Intelligent Power Software	59
6.4	Signal input monitoring.	60
6.5	General purpose relay contact	60
6.6	Configuring relays	60
7	UPS operating instructions	64
7.1	Introduction to UPS operating instructions	64
7.2	UPS controls and indicators	64
7.2.1	Control panel	64
7.2.2	Status indicators.	65
7.2.3	System events	65
7.2.4	Menu structure of the 91PS/93PS UPS	66
7.2.4.1	User settings	67
7.3	Signing in	68
7.4	System control instructions.	68
7.4.1	Starting the UPS system in the double conversion mode	68
7.4.2	Starting the UPS system in the bypass mode	69
7.4.3	Transferring from the double conversion mode to the bypass mode	69
7.4.4	Transferring from the bypass mode to the double conversion mode	70
7.4.5	Transferring from the double conversion mode to the Energy Saver System mode	70
7.4.6	Transferring from the Energy Saver System mode to the double conversion mode	70

7.4.7	Shutting down the UPS system and critical load	70
7.4.8	De-energizing the critical load	71
7.5	Starting a single UPS	71
7.6	Shutting down a single UPS	72
7.7	Enabling and disabling the battery charger	72
7.8	Using the Remote Emergency Power-off switch	72
7.9	Turning the UPS from the double conversion mode to the maintenance bypass mode	73
7.10	Turning the UPS from the maintenance bypass mode to the double conversion mode	74
8	UPS maintenance	77
8.1	UPS maintenance	77
8.2	Important safety instructions	77
8.3	Preventive maintenance	78
8.3.1	Daily maintenance	78
8.3.2	Monthly maintenance	79
8.3.3	Periodic maintenance	79
8.3.4	Annual maintenance	79
8.3.5	Battery maintenance	79
8.4	Recycling the used UPS or batteries	79
8.5	Maintenance training	80
9	Technical data	81
9.1	About technical data	81
9.2	Directives and standards	81
9.3	UPS system input	82
9.4	UPS system output	82
9.5	UPS environmental specifications	83
9.6	Battery specification	84
10	Warranty	85
10.1	General information about warranty	85
10.2	Whom to contact in case of Warranty	85
	APPENDIX A: Recommended security hardening guidelines	86
	Index	89

1 How to read this manual

1.1 Safety-related signs

These are the safety-related signs used in this document.



DANGER

DANGER indicates a hazard with a high level of risk which, if not avoided, may result in serious injury or death.



WARNING

WARNING indicates a hazard with a medium level of risk which, if not avoided, could result in serious injury or death, or damage to the equipment.



CAUTION

CAUTION indicates a hazard with a low level of risk which, if not avoided, could result in minor or moderate injury, or damage to the equipment.

NOTE: Notes are used to indicate important information and useful tips.

1.2 Symbols and abbreviations

Hazard symbols





These symbols indicate a hazardous situation or action. Symbols are used to warn of situations, which can cause environmental damage and personal injury.

	General warning sign
	Explosion and fire hazard
	Battery hazard

	Corrosive hazard
	Electrical hazard



Prohibited action symbols



These symbols are used in warnings and notifications to indicate an action that should not be taken. The prohibited action symbols are shown below.

	No smoking
	Limited or restricted access
	General symbol for prohibited action
	Do not touch

Mandatory action symbols

These symbols are used in warnings and notifications to indicate an action that must be taken. The mandatory action symbols are shown below.

	Wear eye protection
	General symbol for mandatory action

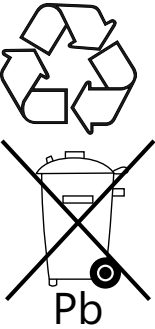
	Read the manual or instructions
	Disconnect from power source
	First aid
	Batteries marked with this sign must be recycled

1.3 Conventions used in this document

This document uses the following type conventions:

Bold type highlights important concepts in discussions, key terms in procedures and menu options, or represents a command or option that you type or enter at a prompt.

Italic type highlights notes and new terms when they are defined.

`Screen` type represents information that appears on the screen or LCD.

1.4 Glossary

The following acronyms are used in Eaton documentation to refer to Eaton UPS products or their parts.

Table 1. Glossary of acronyms

ABM	Advanced Battery Management
EPO	Emergency Power-Off
ESS	Energy Saver System
IPM	Intelligent Power Manager

IPP	Intelligent Power Protector
MBS	Maintenance Bypass Switch
MIS	Maintenance Isolation Switch
MOB	Module Output Breaker
SCR	Silicon-Controlled Rectifier
UPM	Uninterruptible Power Module
UPS	Uninterruptible Power Supply
VRLA	Valve Regulated Lead Acid (battery)

2 Safety instructions

2.1 General safety instructions



DANGER

Important safety instructions!
Keep these instructions!

This document contains important instructions that must be followed during the installation, operation and maintenance of the UPS and the batteries. Read all of the instructions before operating the equipment. Keep this manual for future reference. These instructions are also available for download at www.eaton.eu/93ps.



DANGER

Operations inside the UPS must be performed by an authorized Eaton Field Service Engineer or by other qualified service personnel authorized by Eaton. There are no user-serviceable parts inside the UPS.

The UPS operates with mains, battery or bypass power. It contains components that carry high currents and voltage. A properly installed enclosure is earthed and IP20 rated against electrical shock and foreign objects. However, the UPS is a sophisticated power system and only qualified personnel are allowed to install and service it.



DANGER

This UPS carries lethal voltages. All repairs and service must be performed by authorized personnel only. There are no user-serviceable parts inside the UPS.



WARNING

The UPS is powered by its own energy source (batteries). The output terminals may be energized even when the UPS is disconnected from an AC source. To reduce the risk of fire or electric shock, install this UPS in a temperature and humidity controlled, indoor environment that is free of conductive contaminants.

The ambient temperature must not exceed 40 °C (104 °F) non-condensing conditions. Do not operate the UPS near water or excessive humidity (95% relative humidity maximum). The system is not intended for outdoor use

Before you start any installation or service work, make sure that all AC and DC power sources are disconnected. Power may come from multiple sources. Also ensure system grounding / PE continuity.

In a parallel system, the output terminals may be energized even when the UPS is turned off.



WARNING

Batteries present a risk of electrical shock or burn from high short-circuit current. Obey proper precautions.

Electric energy hazard. Do not attempt to alter any battery wiring or connectors. Attempting to alter wiring can cause injury.

Do not open or mutilate batteries. Released electrolyte may be toxic and is harmful to the skin and eyes.

Batteries may contain HIGH VOLTAGES, and CORROSIVE, TOXIC and EXPLOSIVE substances. Because of the battery string the output receptacles may carry high voltage even when the AC supply is not connected to the UPS. Read the shutdown instructions carefully.

IMPORTANT: The battery may consist of multiple parallel strings. Make sure that you disconnect all strings before installation.



CAUTION

Only qualified service personnel knowledgeable of batteries and the required precautions are allowed to perform installation or service work on batteries. Keep unauthorized personnel away from the batteries. Before you install or replace batteries, consider all the warnings, cautions, and notes concerning appropriate handling. Do not disconnect the batteries when the UPS is in the Battery mode.

Make sure that your replacement batteries are of the same number and type as the battery that was originally installed in the UPS. See more accurate instructions on the UPS.

Before you connect or disconnect battery terminals, disconnect the charging source by opening the corresponding battery circuit breaker.

Examine if the battery is inadvertently grounded. If it is, remove the source of the ground. Contacting any part of a grounded battery can cause a risk of electric shock. If you disconnect the grounding connection before you work on the batteries, the risk of an electric shock is less likely.

Discard batteries according to your local disposal requirements. Do not dispose of batteries in a fire. When exposed to flame, batteries may explode.

To reduce the risk of a fire, connect only to a circuit that has a circuit breaker that is rated in accordance with the national and local installation rules and UPS installation instructions.

To ensure proper cooling airflow and to protect personnel from dangerous voltages inside the unit, keep the UPS door closed and the front panels installed.

Do not install or operate the UPS system close to gas or electric heat sources. Keep the operating environment within the parameters stated in this document.



CAUTION

Keep the surroundings of the UPS uncluttered, clean, and free from excess moisture.

Obey all DANGER, CAUTION, and WARNING notices affixed to the equipment.

2.2 Audience

The intended audience of this document are as follows:

- People who plan and do the installation of the UPS
- People who use the UPS

This document provides guidelines for how to examine the UPS delivery and how to install and operate the UPS.

The reader is expected to know the fundamentals of electricity, wiring, electrical components and electrical schematic symbols. This document is written for a global reader.



CAUTION

Read this document before you start to operate or do work on the UPS.

2.3 CE marking

The product has a CE marking in compliance with the following European directives:

- LVD Directive (Safety) 2014/35/EU
- EMC Directive 2014/30/EU
- RoHS Directive 2011/65/EU

Declarations of conformity with UPS harmonized standards and directives EN 62040-1 (Safety), EN 62040-2 (EMC) and EN 63000 (RoHS) are available at www.eaton.eu or by contacting your nearest Eaton office or authorized partner.

2.4 User precautions

The only permitted user operations are as follows:

- Startup and shutdown of the UPS, excluding the commissioning startup.
- Use of the LCD control panel and the Maintenance Bypass Switch (MBS).
- Use of optional connectivity modules and their software.

Follow the precautions and only perform the described operations. Any deviation from the instructions can be dangerous to the user or cause accidental load loss.



DANGER

Do not open any other screws in the unit than those holding the cover plates of the MiniSlots and the MBS locking plate. Failure to recognize the electrical hazards can prove fatal.



CAUTION

The 8-10 kW models are available as a C2 UPS product in regard to emissions and C3 UPS in immunity. The UPS can be placed both in residential and commercial or industrial environments. When included in a residential environment, this product may cause radio interference, in which case you may have to take additional preventive measures.

2.5 Environment

The UPS must be installed according to the recommendations in this document. Never install the UPS in an airtight room, in the presence of flammable gases, or in an environment exceeding the specifications.

Excessive amount of dust in the operating environment of the UPS may cause damage or lead to malfunction. Always protect the UPS from the outside weather and sunshine. In order to maximize internal battery service life time, the recommended operating temperature range is from +20 °C to +25 °C.



WARNING

During charge, float charge, heavy discharge, and overcharge, hydrogen and oxygen gases are emitted from lead-acid and NiCd batteries into the surrounding atmosphere. Explosive gas mixture may be created if the hydrogen concentration exceeds 4% by volume in air. Ensure the necessary air flow rate for the ventilation of the UPS location.

2.6 Symbols on the UPS and accessories

The following are examples of symbols used on the UPS or its accessories. The symbols are used to alert you of important information.

	<p>RISK OF ELECTRIC SHOCK Indicates that a risk of electric shock is present and the associated warning should be observed.</p>
	<p>CAUTION: REFER TO OPERATOR'S MANUAL Refer to your operator's manual for additional information, such as important operating and maintenance instructions.</p>

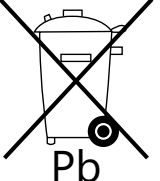
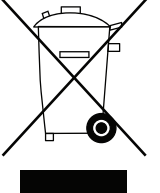
	<p>This symbol indicates that you may not discard the UPS or the UPS batteries in the trash. This product involves sealed, lead-acid batteries and they must be disposed of properly. For more information, contact your local recycling / reuse or hazardous waste center.</p>
	<p>This symbol indicates that you may not discard waste electrical or electronic equipment (WEEE) in the trash. For proper disposal, contact your local recycling / reuse or hazardous waste center.</p>

2.7 For more information

Address any inquiries about the UPS and the battery cabinet to the local office or an agent authorized by the manufacturer. Quote the type code and the serial number of the equipment.

Contact your local service representative if you need help with any of the following.

- scheduling initial startup
- regional locations and telephone numbers
- a question about any of the information in this manual
- a question that this manual does not answer

3 Introduction to Eaton 91PS/93PS 8-10 kW UPS

3.1 About the Eaton UPS

Figure 1. Eaton 91PS/93PS 8-10 kW UPS

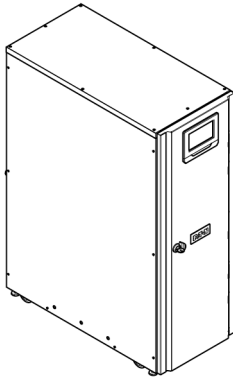

The Eaton® 91PS/93PS 8-10 kW uninterruptible power supply (UPS) is a true online, continuous-duty, transformerless, double-conversion, solid-state, single-/ three-phase system that supplies conditioned and uninterruptible AC power to critical load and protects it from power failures.

The UPS is used to prevent loss of valuable electronic information, minimize equipment downtime, and minimize the adverse effect on production equipment due to unexpected power problems.

The Eaton UPS continually monitors incoming electrical power and removes the surges, spikes, sags, and other irregularities that are inherent in commercial utility power. Working with a building's electrical system, the UPS system supplies clean, consistent power that sensitive electronic equipment require for reliable operation. During brownouts, blackouts, and other power interruptions, batteries provide emergency power to safeguard operation.

The UPS system is housed in a single, free-standing cabinet with safety shields behind the door for protection against hazardous voltage.

NOTE: Startup and operational checks must be performed by an authorized Eaton Field Service Engineer or by other qualified service personnel authorized by Eaton, or the terms specified in the Warranty (see *10.1 General information about warranty*) become void. This service is offered as part of the sales contract for the UPS. Contact service in advance (usually a two-week notice is required) to reserve a preferred startup date.

3.2 Looking inside the UPS system

Figure 2. Looking inside the Eaton 91PS/93PS UPS 8-10 kW standard frame

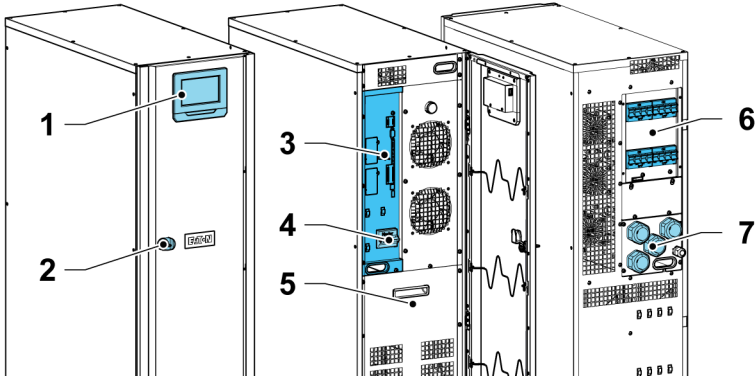

1. Control panel
2. Door latch
3. Communications area
4. Battery breaker
5. Internal battery
6. Switches
7. Client connections

The static bypass line consists of a static switch and a backfeed protection isolation device connected in series. In addition, there is a system level control unit that constantly monitors the power delivered through the bypass line or to the input of the UPS. Transfers to static bypass are seamless and performed automatically by the system as needed, for example, in case of an extended system overload.

Each UPS is able to operate and share the load independently, despite the status of the other UPSs.

The 91PS/93PS UPS 10 kW frame includes rectifier, inverter, battery converter, controls and 10 kW static bypass. In addition to the internal batteries, external batteries can also be connected.



WARNING

Hazardous voltage can exist in the battery circuit until disconnected from external battery source.

The rectifier input switch, battery breaker and internal MBS are available as standard for all the models.

If utility power is interrupted or falls outside the parameters specified in *Chapter 9.1 About technical data*, the UPS uses a backup battery supply to maintain power to the critical load for a specified period of time or until the utility power returns. For extended power outages, the UPS allows you to either transfer to an alternative power system (such as a generator) or shut down your critical load in an orderly manner. The UPS bypass consists of a continuous-duty static switch and a backfeed protection isolation device. All the models also include an internal fuse in the bypass line. The backfeed protection and bypass fuse are located in series with the static switch.

3.3 UPS operating modes

Table 2. UPS operating modes

UPS operating mode	Description
Normal operating modes:	
Double conversion mode	Critical load is supplied by the inverter, which derives its power from rectified utility AC power. In this mode, the battery charger also provides charging current for the battery, if needed.
Energy Saver System (ESS mode)	Critical load is supported securely by utility power through the static bypass switch with double conversion available on-demand with typically less than a 2 ms transition time, should any abnormal condition be detected in the utility. When operating in the ESS mode, the load is protected with inherent surge suppression. Operating the UPS in the ESS mode increases system efficiency, allowing significant savings in energy losses without compromising system reliability.
Other operating modes:	
Stored energy mode	Energy is drawn from a DC backup power source and converted to AC power by the UPS inverter. Most commonly VRLA batteries are introduced to the system for this purpose, and the mode of operation is called the battery mode.
Bypass mode	Critical load is supported directly by utility power through the UPS static switch.

3.3.1 Normal operating modes

This is a UPS with several normal operating modes: Double conversion, Double conversion with VMMS, and ESS with double conversion on-demand. During normal UPS operation, power for the system is derived from a utility input source. *Unit Online*, *Unit Online VMMS*, or *Unit Online ESS* is displayed on the front panel, indicating that the incoming power is within voltage and frequency acceptance windows.

3.3.1.1 Double conversion mode

Figure 3: Path of current through the UPS in the double conversion mode shows the path of electrical power through the UPS system when the UPS is operating in the double conversion mode.

Figure 3. Path of current through the UPS in the double conversion mode

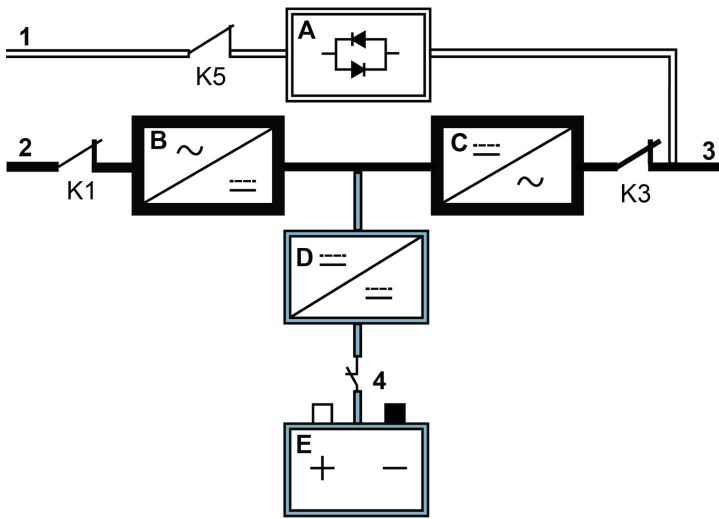

A	Static switch	1	Bypass input		Main power flow
B	Rectifier	2	Rectifier input		Energized
C	Inverter	3	Output		De-energized
D	Battery converter	4	Battery breaker		Trickle current
E	Battery		Closed		Open

Single-/three-phase AC input power is converted to DC using a multilevel converter with IGBT devices to produce a regulated DC voltage to the inverter. The UPS status indicated on the display is *Unit Online* and the UPM status is *Active*.

The battery converter derives its input from the regulated DC output of the rectifier and provides regulated charge current to the battery. The battery is always connected to the UPS and ready to support the inverter should the utility input become unavailable.

The inverter produces a single-/three-phase AC output to the critical load. The inverter uses multilevel converter technology with IGBT devices and pulse-width modulation (PWM) to produce a regulated and filtered AC output.

If the utility AC power is interrupted or is out of specification, the UPS automatically switches to the battery mode to support the critical load without interruption. When utility power returns, the UPS returns automatically to the double conversion mode.

If the UPS becomes overloaded or unavailable, the UPS seamlessly switches to the bypass mode and continues supplying the load through the static bypass. The UPS automatically returns to the double conversion mode when the abnormal condition, such as an extended time overload, is cleared and the system operation is restored within the specified limits.

If a UPM within the UPS suffers an internal failure, the remaining UPMs continue to support the load in the double conversion mode. The UPS is automatically internally redundant when the UPS is not operating at full load. However, if internal redundancy between the UPMs is not possible due to high load, the UPS switches automatically to the bypass mode and remains in that mode until the failure is corrected and the

UPS is back in operation.

In an external parallel redundant system, each UPS can be isolated from the system for service while the remaining UPSs support the load in the double conversion mode.

3.3.1.2 Energy Saver System mode

Figure 4: Path of current through the UPS in the Energy Saver System mode shows the path of electrical power through the UPS system when the UPS is operating in the Energy Saver System (ESS) mode.

Figure 4. Path of current through the UPS in the Energy Saver System mode

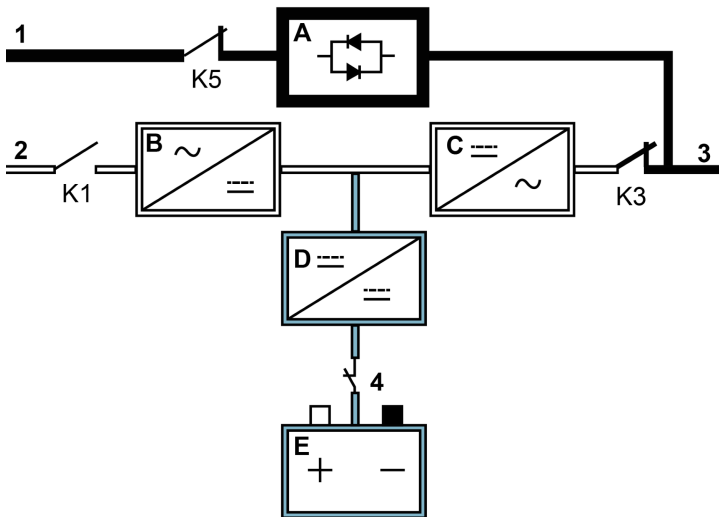

A	Static switch	1	Bypass input		Main power flow
B	Rectifier	2	Rectifier input		Energized
C	Inverter	3	Output		De-energized
D	Battery converter	4	Battery breaker		Trickle current
E	Battery				Closed
					Open

In the ESS mode, the UPS safely provides mains current directly to the load when the input is within the acceptable limits by its voltage and frequency. The UPS status indicated on the display is *Unit Online ESS*, and the UPM status is *Active*. Surge board is no longer used in UPS design. In case any disturbances are detected in the incoming power, the UPS switches to the double conversion mode and continues to supply the critical load through its inverter. In case of a complete utility outage or if the input power is outside the tolerances of the system, the UPS transfers to the battery mode and continues to supply conditioned, clean power to the critical load.

When operating in the ESS mode, the UPS's superior detection and control algorithms continuously monitor the incoming power quality and allow fast engagement of the power converters. Typical transition time to the double conversion mode is less than 2 milliseconds, which is practically seamless.

When the power conditions are within acceptable limits, the UPS operates as a high efficiency, energy-saving system, providing surge protection for IT equipment and making sure that clean power is delivered to the facility. The energy saver system increases system efficiency up to 99 % when supplying 20-100 % of nominal load, reducing energy losses by up to 80 %.

3.3.2 Stored energy and battery mode

When running normally in the double conversion or ESS mode, the UPS automatically transfers to supply the load from batteries or some other stored energy source if a utility power outage occurs, or if the utility power does not conform to the specified parameters. The UPS status indicated on the display is *On Battery*, and the UPM status is *Active*. In the battery mode, the battery provides emergency DC power, which is converted to regulated output power by the inverter.

Figure 5: Path of current through the UPS in the battery mode shows the path of electrical power through the UPS system when operating in the battery mode.

Figure 5. Path of current through the UPS in the battery mode

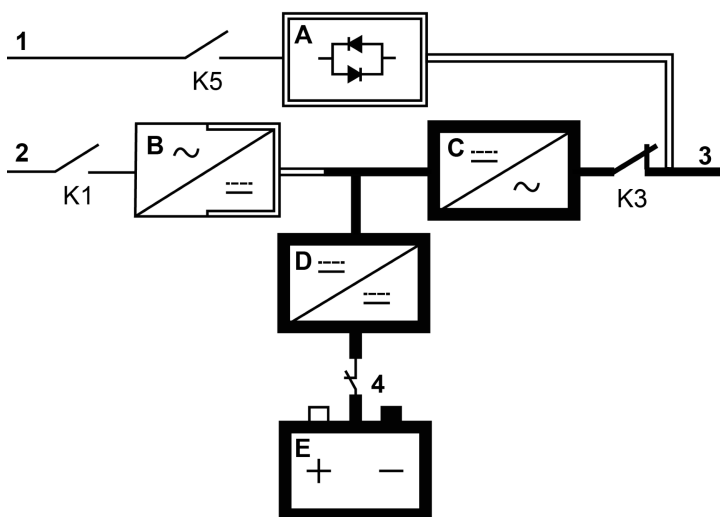

A	Static switch	1	Bypass input		Main power flow
B	Rectifier	2	Rectifier input		Energized
C	Inverter	3	Output		De-energized
D	Battery converter	4	Battery breaker		Trickle current
E	Battery		Closed		Open

During a utility power failure, the rectifier no longer has an AC utility source from which to supply the DC output current required to support the inverter. The input relay K1 opens and the UPS output is powered from the batteries through the inverter. As the inverter operates uninterrupted through the transition, the load remains supported continuously without disturbance. If the UPS static bypass is supplied from the same source as the UPS rectifier, the backfeed protection contactor K5 also opens. The opening of K1 and K5 prevent system voltages from bleeding backwards and re-entering the input source through the static switch or rectifier.

If the input power fails to return or is not within the acceptance windows required for normal operation, the battery continues discharging until a DC voltage level is reached where the inverter output can no longer support the connected loads. When this event occurs, the UPS issues a set of audible and visual alarms indicating that the batteries have a minimal capacity left and a system shutdown is imminent. Unless utility power is restored, the output can be supported for a maximum of 2 minutes before the output of the system shuts down. If the bypass source is available, the UPS transfers to the bypass mode instead of shutting down.

If the input power becomes available again at any time during the battery discharge, K1 and K5 close and the UPS returns to normal operation. The UPS also starts to recharge the batteries to restore the capacity.

3.3.3 Bypass mode



CAUTION

The critical load is not protected while the UPS is in bypass mode.

The UPS automatically switches to the bypass mode if it detects an overload, load fault, or internal failure. The bypass source supplies the commercial AC power to the load directly. The UPS can also be commanded to transfer to the bypass mode manually through the display. The UPS status indicated on the display is *On Bypass*.

The UPS will return from the bypass mode back to online mode, if the condition (for example overload) that caused the transfer is cleared. If there is a condition that will not clear by itself (for example UPS internal failure), the UPS will remain on bypass operation.

Figure 6: Path of current through the UPS in the bypass mode shows the path of electrical power through the UPS system when operating in the bypass mode.

Figure 6. Path of current through the UPS in the bypass mode

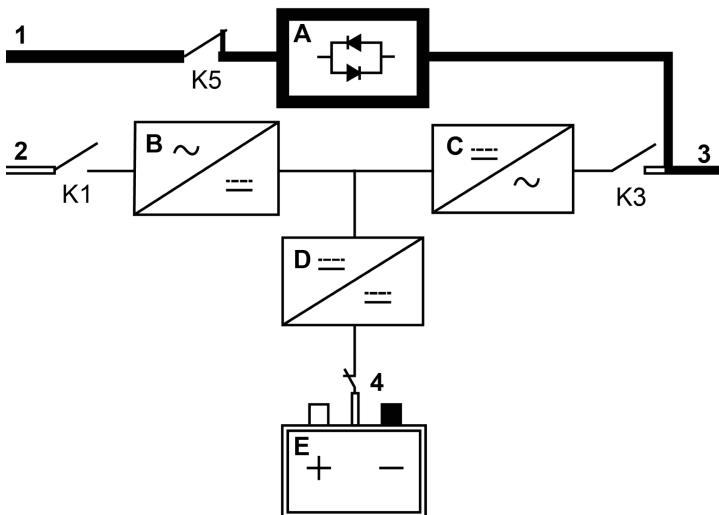

A	Static switch	1	Bypass input		Main power flow
B	Rectifier	2	Rectifier input		Energized

C	Inverter	3	Output	—————	De-energized
D	Battery converter	4	Battery breaker	=====	Trickle current
E	Battery	∩	Closed	∩	Open

In the bypass mode, the output of the system is provided with AC power directly from the system input. While in this mode, the output of the system is not protected from voltage or frequency fluctuations or power outages from the source. Some power line filtering and transient protection is provided to the load, but no active power conditioning or battery support is available to the output of the system in the bypass mode.

The static bypass consists of a solid-state, silicon-controlled rectifier (SCR) static switch (STSW) and a backfeed protection isolation device K5. The static switch is rated as a continuous-duty device that is used anytime the inverter is unable to support the applied load. The static switch is wired in series with the backfeed protection. As the static switch is an electronically-controlled device, it can be turned on immediately to pick up the load from the inverter without interruption. The backfeed protection is normally always closed, ready to support the static switch unless the bypass input source becomes unavailable.

3.3.4 Maintenance Bypass Switch

The Maintenance Bypass Switch (MBS) enables power to completely bypass and isolate the UPS so that the UPS can be safely serviced or replaced without interrupting power to critical systems.

An internal Maintenance Bypass Switch is provided as a standard. The MBS functionality is formed by four separate switches:

- Rectifier Input Switch (RIS)
- Bypass Input Switch (BIS)
- Maintenance Isolation Switch (MIS)
- Maintenance ByPass (MBP)

Alternatively, MBS solutions are also available in an external enclosure as accessory items.

Figure 7. UPS wiring diagram including MBS

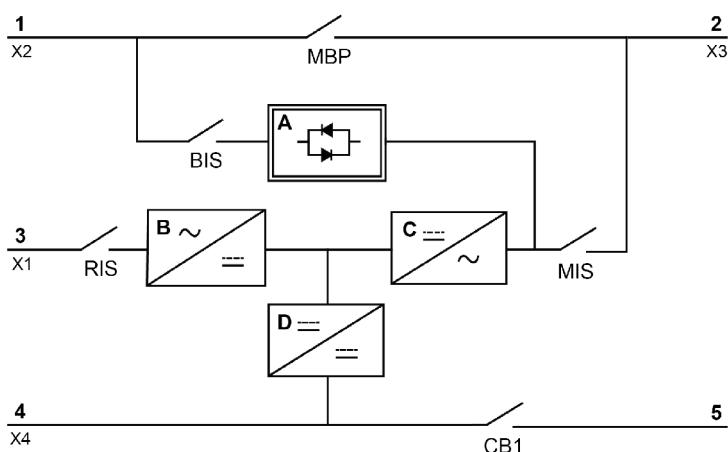

1	Bypass input	4	External battery
2	Output	5	Internal battery
3	Rectifier input		

3.4 UPS features

The Eaton UPS has many features that provide cost-effective and consistently reliable power protection. The feature descriptions provide a brief overview of the UPS standard features.

3.4.1 Advanced Battery Management

The Advanced Battery Management (ABM) technology uses sophisticated sensing circuitry and a three-stage charging technique that extends the useful service life of UPS batteries while optimizing the battery recharge time. The UPS also protects batteries from damage caused by high current charging and inverter ripple currents. Charging at high currents can overheat and damage batteries.

In the charge mode, the batteries are recharged. Charging lasts only as long as it takes to bring the battery system up to a predetermined float level. Once this level is reached, the UPS battery charger enters the float stage and the charger operates in the constant voltage mode.

The rest mode begins at the end of the float charge mode; that is, after 48 hours of float charging (user-adjustable). In the rest mode, the battery charger is completely turned off. The battery system receives no charge current during this rest period of approximately 28 days (user-adjustable). During the rest mode, the open circuit battery voltage is monitored constantly, and battery charging is resumed when necessary.

3.4.2 Powerware Hot Sync

The Eaton Powerware Hot Sync technology is an algorithm that eliminates the single point of failure in a parallel system and therefore enhances system reliability. The Hot Sync technology is incorporated in all three-phase Eaton UPSs, and it is utilized in both multi-module internal parallel and external parallel systems.

The Hot Sync technology enables all UPMs to operate independently in a parallel system, even without inter-module communications. The power modules utilizing the Hot Sync technology are completely autonomous; each module monitors its own output independently to remain in complete synchronization with the other modules. The UPM power modules share the load perfectly even in changing capacity or load conditions.

The Powerware Hot Sync technology combines digital signal processing and an advanced control algorithm to provide automatic load sharing and selective tripping in a parallel UPS system. The load share control algorithms maintain synchronization and load balance by constantly making minute adjustments to variations in the output power requirements. The modules conform to demand and are not in conflict with each other for the load. The Powerware Hot Sync systems are capable of paralleling for both redundancy and capacity.

3.4.3 Power Conditioner

The Power Conditioner mode is characterized by the UPS running in the double conversion mode without batteries connected. In the Power Conditioner mode, the UPS provides conditioned output voltage and frequency. The UPS can also support high nonlinear loads without ITHD on the input. The UPS meets the qualifications outlined in this product specification, except for the conditions below.

When in the Power Conditioner mode, the UPS has the following functionality and limitations:

1. The UPS runs in the double conversion mode and the battery alarms are turned off.
2. Because there is no battery, loss of utility power results in the UPS losing power and shutting down.
3. The UPS sustains up to -50% input voltage tolerance, unless the current limit is reached.
4. If the rectifier is turned off, the UPS attempts a transfer to the bypass mode.
5. The ESS mode is not available.

3.4.4 Frequency Converter

The Frequency Converter mode is characterized by the UPS running without the bypass mode available. The output frequency can be configured to be different from the standard input frequency (for example, 60 Hz output, 50 Hz input). The UPS can also support high nonlinear loads without iTHD on the input. The UPS meets the qualifications outlined in this product specification, except for the conditions below.

When in the Frequency Converter mode, the UPS has the following functionality and limitations:

1. Operation is the same as when in the double conversion mode with no bypass available.
2. Bypass alarms are suppressed.

3.5 Software and connectivity features

3.5.1 User interface

MiniSlot Communication Bays - there are 2 communication bays for MiniSlot connectivity cards. MiniSlot cards are quickly installed and are hot-pluggable. See *Chapter 6.1 Introduction to communication interfaces* for additional information.

3.5.2 Power Management Software

Intelligent Power software products offer tools for monitoring and managing power devices across the network. See *Chapter 6.1 Introduction to communication interfaces* for more information.

3.6 Options and accessories

Contact your Eaton sales representative for more information about the available options and accessories.

3.6.1 External Maintenance Bypass Switch Panel (accessory)

The external MBS is enclosed in its own separate cabinet, which can be either a wall-mounted or stand-alone cabinet depending on the MBS power rating. The MBS wiring has two different options: two- and three-switch configuration. The two-switch model contains a maintenance isolation switch and a maintenance bypass switch. In addition to these, the three-switch model contains a bypass input breaker. The external MBS enclosures are IP22 classified.

The two-switch model assumes that the UPS rectifier and bypass are coupled through dedicated breakers and separate cables from the switchgear. However, the three-switch model can be connected to the switchgear with only a single cable, and the cable connections between the panel and UPS are run separately.

For external MBS installation instructions, see the installation instruction shipped with the unit.

3.7 Battery system

The battery system provides short-term emergency backup power to safeguard operation during brownouts, blackouts, and other power interruptions. By default, UPS is configured to use VRLA batteries. If other type of batteries or other energy storage means need to be connected, consult a certified service technician prior to proceeding with the installation.

The Eaton 91PS/93PS 8-10 kW UPS are equipped with internal batteries to provide full load runtime of 5...10 minutes depending on the UPS rating. In addition, a battery sidecar and external battery cabinets can be introduced to the system to allow extended autonomy. Internal and external batteries can be used in parallel.

For detailed battery specifications, see *Chapter 9.1 About technical data*.

3.8 Basic system configurations

UPS power rating

Table 3. UPS configurations

Description	System power [kW]	Static switch [kW]	Internal battery
91PS-8(10)	8	10	Yes/No
91PS-10(10)	10	10	Yes/No
93PS-8(10)	8	10	Yes/No
93PS-10(10)	10	10	Yes/No

UPS options and accessories

The following table shows the features of 91PS/93PS 8-10 kW UPS.

Table 4. Standard UPS features

Feature	91PS/93PS 8–10 kW
Smart touch screen display for system control and monitoring	Standard
SNMP web interface	Standard
Internal MBS	Standard
Rectifier input switch RIS	Standard
Internal battery breaker CB1	Standard
Battery start	Standard
Integrated backfeed protection	Standard

Additional options and accessories are also available. These include different software and connectivity options and external switchgear and power distribution options.

4 UPS installation plan and unpacking

4.1 To install the UPS

Use the following basic sequence of steps to install the UPS:

1. Create an installation plan for the UPS system.
2. Prepare your site for the UPS system.
3. Inspect and unpack the UPS cabinet.
4. Unload and install the UPS cabinet and wire the system.
5. Complete the installation checklist provided in *Section 4.3 Installation checklist*.
6. Have authorized service personnel do the preliminary operational checks and startup.

NOTE: Startup and operational checks must be done by an authorized Eaton Field Service Engineer or by other qualified service personnel authorized by Eaton, or the terms specified in the Warranty (see *Section 10.1 General information about warranty*) become void. This service is offered as a part of the sales contract for the UPS. Contact service in advance (usually a two-week notice is required) to reserve a preferred startup date.

4.2 Create an installation plan

Before you install the UPS system, read and understand how these instructions apply to the system that you are going to install. Use the procedures and illustrations in *Section 4.4 Site preparations* and *Chapter 5.1 Introduction to UPS system installation* to create a logical plan for installing the system.

4.3 Installation checklist

Table 5. Installation checklist

Action	Yes/No
All packing materials and restraints are removed from each cabinet.	
Each cabinet in the UPS system is placed in its installed location.	
A cabinet grounding kit / mounting kit is installed between any cabinets that are bolted together.	
All conduits and cables are properly routed to the UPS and any ancillary cabinets.	
All power cables are properly sized and terminated.	
Neutral conductors are installed and bonded to ground according to the requirements.	
A ground conductor is properly installed.	
Battery cables are terminated and connected to battery connectors.	

Action	Yes/No
Battery Shunt trip and Aux contact signal wiring is connected from the UPS to the battery breaker.	
LAN drops are installed.	
All LAN connections are completed.	
Air conditioning equipment is installed and operating correctly.	
There is adequate workspace around the UPS and other cabinets.	
Adequate lighting is provided around all the UPS equipment.	
A 230 VAC service outlet is located within 7.5 meters of the UPS equipment.	
The Remote Emergency Power-off (REPO) device is mounted in its installed location and its wiring is terminated inside the UPS cabinet.	
If EPO is used in the NC configuration, a jumper is installed on the EPO between pins 1 and 2.	
(OPTIONAL) Alarm relays and signal outputs are wired appropriately.	
(OPTIONAL) A remote battery disconnect control is mounted in its installed location and its wiring is terminated inside the UPS and battery cabinet.	
(OPTIONAL) Accessories are mounted in their installed locations and their wiring is terminated inside the UPS cabinet.	
Start-up and operational checks are performed by an authorized Eaton Field Service Engineer.	

4.4 Site preparations

For the UPS system to operate at peak efficiency, the installation site must meet the environmental parameters outlined in these instructions. If the UPS needs to be operated at an altitude higher than 1,000 m, contact your service representative for important information about high altitude operation. The operating environment must meet the height, clearance, and environmental requirements specified.

4.4.1 Environmental considerations

Install the UPS to a temperature and humidity controlled indoor area, free of conductive contaminants. Do not expose the UPS to direct sunlight or install it near a heat source. The environmental requirements specified in *Section 9.5 UPS environmental specifications* are for the air at the intake ports of the UPS, and are the maximum, not to exceed, ratings.

- Do not expose the UPS for overly aggressive environments, like salt mist or corrosive gases. High relative humidity accelerates the effects of contaminants. The UPS should be installed in a G1 environment (based on ANSI/ISA S-71.04 classifications). If the UPS is used in a more aggressive environment, it can cause reduced product life and possibly early failure. If the installation location does not meet the recommended environment, contact Eaton service representative for further information.

- Do not place the UPS near a source of dust or sand. Excessive amount of dust or sand can cause damage or lead to malfunction.

Observe caution regarding UPS operating environmental conditions. The newer, more energy efficient data center cooling methods (such as air side economizing) can create much wider ranges of temperature and Relative Humidity (RH) in the UPS room and/or data center. There are two aspects of this increased operating environment that can, if ignored, create issues:

- The creation of micro climates, which are persistent variations of temperature and/or RH within a single room; for example one side of the room is always cooler than the other side, no matter what the actual temperature is.
- The rate of change of temperature and/or RH, which can occur during transitions within the cooling system. Examples: changing the mixture ratio of inside versus outside air, or external changes in the outside air when going from night time into day, and back to night.

When ignored, either one of these aspects can create an undesirable micro climate at the UPS location. If the environment created by this micro climate exceeds the UPS operating specification, the UPS reliability is reduced over time. These same environmental extremes create also reliability concerns for any servers that are exposed to them.

4.4.2 Installation considerations

The UPS system installation requires a TN, TT or IT power distribution system (the IT distribution system shall include a neutral wire).

The UPS system installation must meet the following guidelines:

- The system must be installed on a level floor suitable for computer or electronic equipment. The floor must be suitable for heavy weight and wheeling.
- The system must be installed in a temperature and humidity controlled indoor area that is free of conductive contaminants.
- The cabinet can be installed in line-up-and-match or standalone configurations.

Failure to obey these guidelines may void your warranty.



CAUTION

Do not stack anything on top of the 91PS/93PS UPS cabinet.



CAUTION

If the unit is installed in an IT network, the voltage between neutral and protective earth during normal operation must be less than 50 V (AC, RMS), 71 V (AC, peak) or 120 V (DC).



CAUTION

This product can cause a DC current in the PE conductor. Where a residual current-operated protective device (RCD) is used for protection against electrical shock, only an RCD of Type B is allowed on the supply side of this product.

The UPS equipment operating environment must meet the weight requirements shown in *Table 7: UPS cabinet weights with cardboard packaging*, and the size requirements shown in *Table 6: Dimensions*.

Table 6. Dimensions

	8-10 kW [mm]	8-10 kW with battery sidecar [mm]
Shipping dimensions (WxDxH)	630 x 800 x 1111	630 x 800 x 1111 and 1200 x 800 x 554*
Cabinet dimensions (WxDxH)	335 x 750 x 950	494 x 750 x 950

* The battery sidecar is shipped separately.

Table 7. UPS cabinet weights with cardboard packaging

	8-10 kW [mm]	8-10 kW with battery sidecar [mm]
Shipping weight with batteries	188 kg	188 kg and 130 kg *
Installed weight with batteries	163 kg	266 kg
Shipping weight without batteries	98 kg	N/A
Installed weight without batteries	73 kg	N/A
Floor loading	700 kg/m ²	770 kg/m ²

* The battery sidecar is shipped separately.

NOTE: Maximum number of internal batteries are included.

The UPS cabinets use forced air cooling to regulate internal component temperature. By default, air inlets are in the front of the cabinet and outlets are in the back. Allow clearance in front of and behind each cabinet for proper air circulation.

The clearance required around the UPS cabinet is shown in *Table 8: UPS cabinet minimum clearances*.

NOTE: This equipment is not intended for building-in, rack-mounting or for incorporation in larger equipment.

Table 8. UPS cabinet minimum clearances

	8-10 kW
From the top of the cabinet	500 mm
From the front of the cabinet	500 mm
From the back of the cabinet	150 mm
From the side of the cabinet	0 mm (500 mm)*
<i>NOTE: No side clearance required if the unit can be pulled out for side access. This requires approximately 1.5 m increase to power and signal cable lengths.</i>	

Figure 8. UPS cabinet clearances

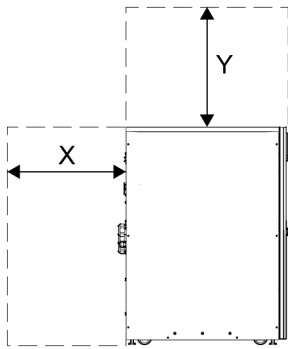

- X = clearance at the back of the UPS cabinet
- Y = clearance at the top of the UPS cabinet

The basic environmental requirements for the operation of the UPS system are as follows:

- Ambient temperature range: from +0 to +40 °C
- Recommended operating range: from +20 to +25 °C
- Maximum relative humidity: 95%, non-condensing

It is required that ventilation of the UPS room is arranged. Sufficient amount of air cooling is needed to keep the maximum room temperature rise at the desired level:

- In order to limit the temperature rise to a maximum of +5 °C, the required air flow is 600 m³/h per 1 kW of losses.
- To limit the temperature rise to a maximum of +10 °C, the required air flow is 300 m³/h per 1 kW of losses.

An ambient temperature from +20 °C to +25 °C is recommended to achieve a long life of the UPS and batteries. The cooling air that enters the UPS must not exceed +40 °C. Avoid high ambient temperature, moisture, and humidity.

For ventilation requirements, see 91PS/93PS heat rejection in *Table 9: Air conditioning or ventilation requirements during full load operation*.

Table 9. Air conditioning or ventilation requirements during full load operation

	Heat rejection (BTU/h x 1,000)	Heat rejection (kW)
8 kW	1.17	0.3
10 kW	1.46	0.4

Battery locations and enclosures must be ventilated to maintain the hydrogen concentration below the 4% vol safety limit. Adequate air ventilation must be provided to locations where the UPS and batteries are located. For the 91PS/93PS UPS 8-10 kW with internal batteries, the minimum air flow is 1.5 m³/hour and the minimum free area of opening for inlet and outlet is 42 cm² when natural ventilation is used. For larger batteries, the ventilation air flow must be recalculated.

Figure 9. Dimensions of Eaton 91PS/93PS UPS 8-10 kW without and with a side car

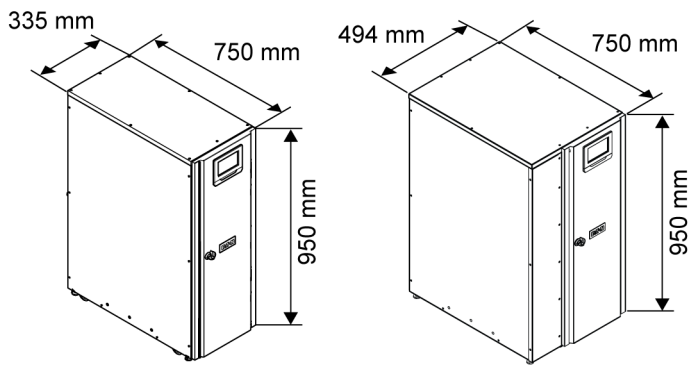

4.4.3 UPS system power wiring preparations

NOTE: If you are installing a maintenance bypass, provide one of the following:

- a minimum of 2 separate feeds with upstream feeder breakers
- a single feed with 2 upstream feeder breakers: one for the UPS or rectifier input breaker and one for the maintenance bypass input.

NOTE: Do not use a single feed or a single feeder breaker to supply

- the maintenance bypass and the UPS, or
- the maintenance bypass and the rectifier input breaker.

NOTE: If a bypass input breaker is installed in the maintenance bypass and a single-feed UPS is being installed, a single feed to the maintenance bypass is acceptable for supplying both the UPS and the bypass.

When you plan and perform the installation, read and understand the following notes.



WARNING

HIGH TOUCH CURRENT. EARTH CONNECTION ESSENTIAL BEFORE CONNECTING SUPPLY. As a result of the connected loads high leakage current is possible. Connection of the earth (ground) is required for proper product operation. Do not check UPS operation by removal of the earth (ground) connection.

- Refer to the national and local electrical codes for acceptable external wiring practices.
- To allow for future kVA upgrades (software), consider using conductors that are sized for the full bypass rating of the UPS.
- Material and labor for external wiring requirements must be provided by designated personnel.
- For external wiring, use copper cable rated for 70 °C at minimum. See the appropriate information in *Tables 10: Minimum recommended multi-core cable and fuse sizes for rectifier and bypass input and UPS output cables (3 phase input, 3 phase output models)*, *11: Minimum recommended multi-core cable and fuse sizes for rectifier input, bypass input and UPS output cables (3 phase input, 1 phase output)* and *12: Minimum recommended multi-core cable and fuse sizes for rectifier and bypass input and UPS output cables (1 phase input, 1 phase output)*. Cable sizes are based on using the specified breakers.

- If cables are run in an ambient temperature greater than 30 °C, higher temperature cable and/or larger size cable may be necessary.
- The bypass feed into this equipment uses four wires. The rectifier feed into this equipment uses three or four wires. The phases must be symmetrical about ground (from a Wye source) for proper equipment operation.
- If the load requires a neutral, a bypass source neutral must be provided. If the load does not require a neutral and there is no neutral conductor connected at the bypass input, a neutral must be installed to source star point.
- A readily accessible disconnect device must be incorporated in all fixed input wiring.



WARNING

Do not disconnect the bypass neutral without disconnecting the bypass phases at the same time.

Table 10. Minimum recommended multi-core cable and fuse sizes for rectifier and bypass input and UPS output cables (3 phase input, 3 phase output models)

UPS rating (kW)	8	10
Cable [mm ²]*	4x2.5	4x4
Rectifier fuse [A]	16	20
Bypass fuse [A]	16	20
PE cable [mm ²]	2.5	4
Maximum conductor cross section	Solid/stranded wire 16mm ² Stranded wire with ferrule: 10 mm ²	
Tightening torque [Nm]	1.6 Nm (L, N) 10 Nm for 16–35 mm ² wire (PE) 6 Nm for 4–10 mm ² wire (PE) 4 Nm for 2.5 mm ² wire (PE)	
* Minimum recommended		

Table 11. Minimum recommended multi-core cable and fuse sizes for rectifier input, bypass input and UPS output cables (3 phase input, 1 phase output)

UPS rating (kW)	8	10
Rectifier input, cable [mm ²]*	3x2.5	3x4
Rectifier fuse [A]	16	20
Rectifier input, PE cable [mm ²]*	2.5	4
Bypass input and UPS output, cable [mm ²]*	10	16
Bypass fuse [A]	50	63
Bypass input and UPS output, PE cable [mm ²]	10	16
Maximum conductor cross section	Solid/stranded wire 50 mm ²	

UPS rating (kW)	8	10
	Stranded wire with ferrule: 35 mm ²	
Tightening torque [Nm]	3.5 Nm (L, N) 10 Nm for 16–35 mm ² wire (PE) 6 Nm for 4–10 mm ² wire (PE) 4 Nm for 2.5 mm ² wire (PE)	
* Minimum recommended		

Table 12. Minimum recommended multi-core cable and fuse sizes for rectifier and bypass input and UPS output cables (1 phase input, 1 phase output)

UPS rating (kW)	8	10
Cable [mm ²]*	10	16
Rectifier fuse [A]	50	63
Bypass fuse [A]	50	63
PE cable [mm ²]	10	16
Maximum conductor cross section	Solid/stranded wire 50 mm ² Stranded wire with ferrule: 35 mm ²	
Tightening torque [Nm]	3.5 Nm (L, N) 10 Nm for 16–35 mm ² wire (PE) 6 Nm for 4–10 mm ² wire (PE)	
* Minimum recommended		

Table 13. Minimum required short-circuit current ratings for AC source and battery supply

UPS model	Minimum short circuit current, AC ports [kA]	Minimum short circuit current, battery port [kA]
91PS 8-10 kW	0,6	N/A The SCPD are in the external battery cabinets



CAUTION

Make sure that prospective short-circuit current resulting at the UPS input terminals is equal or less than conditional short-circuit current declared on the type plate (and technical specification) of the UPS. Also make sure that the prospective short-circuit current meets the minimum requirements listed in *Table 13: Minimum required short-circuit current ratings for AC source and battery supply*.

Table 14. Minimum recommended cable and fuse sizes for external battery bank

UPS rating (kW)	8	10
Pos & neg line [mm ²]*	10	10
Battery fuse [A]	32	32
PE cable [mm ²]	10	10
Maximum conductor cross section	Solid wire: 25 mm ² Stranded wire with ferrule: 16 mm ²	
Tightening torque [Nm]	3 Nm (Pos. & Neg. line) 10 Nm for 16-35 mm ² wire (PE) 6 Nm for 4-10 mm ² wire (PE)	
* Minimum recommended		

NOTE: UPS power upgrading is possible only if the sizing of the external cables is sufficient. Alternatively, the external cabling must be upgraded as well. Fuses are of the type gG.
Cable sizing is based on the standard IEC 60364-5-52 table B.52.2 and IEC 60364-5-54 table B.54.2.
Sizing is for 70 °C rated copper cables.

When connecting external batteries to 91PS/93PS UPS, Eaton recommends that you use the following circuit breakers:

	Type	Article No	Nominal battery voltage	12V VRLA Blocks
With 91PS/ 93PS 8–10 kW	FAZ-C32/2-DC	279143	336...432 V	28...36
	NZMH2-A32	281283	444–480 V	37...40

NOTE: Contact your Eaton sales representative for more information about the circuit breakers, or if you need help choosing the right model for your UPS system.

Use the following 24 V shunt release with early-make auxiliary contact together with the above circuit breaker:

	Type	Article No
Shunt release	ZP-ASA/24	248438
Aux. contact	ZP-IHK	286052

Table 15. Rated and maximum currents for rated power and voltage (93PS)

Rated power [kW]	Rated voltage [V]	Rectifier input		UPS output / bypass		Battery	
		Rated current [A]	Maximum current [A]	Rated current [A]	Maximum current [A]	Rated current [A]	Maximum current [A]
8	380	13	15	12	18	22	26
	400	12	14	12	17	22	26

Rated power [kW]	Rated voltage [V]	Rectifier input		UPS output / bypass		Battery	
		Rated current [A]	Maximum current [A]	Rated current [A]	Maximum current [A]	Rated current [A]	Maximum current [A]
10	415	12	14	11	16	22	26
	380	16	19	15	22	27	33
	400	15	18	14	21	27	33
	415	15	17	14	20	27	33

Table 16. Rated and maximum currents for rated power and voltage (91PS 3:1)

Rated power [kW]	Rated voltage [V]	Rectifier input		UPS output / bypass	Battery	
		Rated current [A]	Maximum current [A]	Rated current [A]	Rated current [A]	Maximum current [A]
8	380/220	13	15	36	22	26
	400/230	12	14	35	22	26
	415/240	12	14	33	22	26
10	380/220	16	19	45	27	33
	400/230	15	18	43	27	33
	415/240	15	17	42	27	33

Table 17. Rated and maximum currents for rated power and voltage (91PS 1:1)

Rated power [kW]	Rated voltage [V]	Rectifier input		UPS output / bypass	Battery	
		Rated current [A]	Maximum current [A]	Rated current [A]	Rated current [A]	Maximum current [A]
8	220	38	46	36	22	26
	230	37	44	35	22	26
	240	35	42	33	22	26
10	220	48	57	45	27	33
	230	46	55	43	27	33
	240	44	53	42	27	33

NOTE: 1. Maximum rectifier current calculated at the -15% voltage tolerance and 102% continuous overload.
 2. Maximum output/bypass current calculated at continuous 125% overload and at -15% voltage tolerance.
 3. Maximum battery current calculated at rated load and 1.67 V cell voltage for the default 32 block string length.

Figure 10. UPS power cable terminals for three-phase units

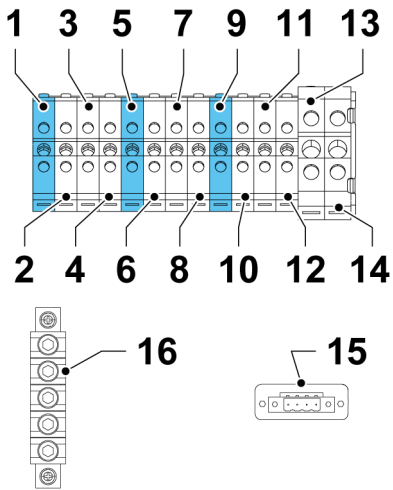

1	X1: rectifier input N	9	X3: UPS output N
2	X1: rectifier input L1	10	X3: UPS output L1
3	X1: rectifier input L2	11	X3: UPS output L2
4	X1: rectifier input L3	12	X3: UPS output L3
5	X2: bypass input N	13	X4: external battery cable +
6	X2: bypass input L1	14	X4: external battery cable –
7	X2: bypass input L2	15	TB20, external battery trip
8	X2: bypass input L3	16	PE

Figure 11. UPS power cable terminals for single phase units

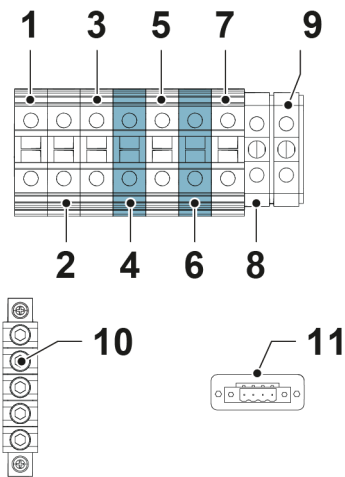

1	X1: rectifier input L1	7	X3: UPS output L
2	X1: rectifier input L2	8	X4: external battery cable +
3	X1: rectifier input L3	9	X4: external battery cable –
4	X1: bypass input N	10	PE
5	X2: bypass input L	11	TB20, external battery trip
6	X3: UPS output N		

NOTE: External overcurrent protection is not provided by this product, but is required by codes. Refer to *Tables 10: Minimum recommended multi-core cable and fuse sizes for rectifier and bypass input and UPS output cables (3 phase input, 3 phase output models)*, *11: Minimum recommended multi-core cable and fuse sizes for rectifier input, bypass input and UPS output cables (3 phase input, 1 phase output)* and *12: Minimum recommended multi-core cable and fuse sizes for rectifier and bypass input and UPS output cables (1 phase input, 1 phase output)* for wiring requirements. If a lockable output disconnect is required, it must be supplied by the user.



CAUTION

To reduce the risk of a fire, connect only to a circuit that is provided with maximum input circuit breaker current ratings in accordance with the national and local installation rules.

The line-to-line unbalanced output capability of the UPS is limited only by the full load per phase current values for AC output to critical load shown in *Tables 15: Rated and maximum currents for rated power and voltage (93PS)*, *16: Rated and maximum currents for rated power and voltage (91PS 3:1)* and *17: Rated and maximum currents for rated power and voltage (91PS 1:1)*. The recommended line-to-line load unbalance is 50% or less.

Source protection for the AC input to bypass must suit the characteristics of the load and take into account effects such as inrush or starting current.

Bypass input and output overcurrent protection and bypass, output and accessory disconnect switches must be provided by the user.

4.5 Unpack and unload the UPS

Before you start to unpack and unload the UPS, look at the TipNTell indicator on the package surface. When you have unpacked and unloaded the UPS, look at the DropNTell indicator on the back of the UPS. If the equipment has been correctly transported in the upright position, the indicators should be intact. If the TipNTell indicator arrow has turned all blue or the arrow head(s) of the DropNTell are black, contact the appropriate parties to report inappropriate transportation.



WARNING

The UPS cabinet is heavy. If you do not obey the unpacking instructions, the cabinet may tip over and cause serious injury.

Do not tilt the UPS cabinet more than 10 degrees from the vertical or the cabinet may tip over.

For transportation purposes, the UPS cabinet is bolted onto a wooden pallet. To remove the pallet, do the following:

1. Before you unload the cabinet from the pallet, use a forklift or other material handling equipment to move the cabinet to the installation area. Insert the forks of the forklift between the skids on the bottom of the unit.

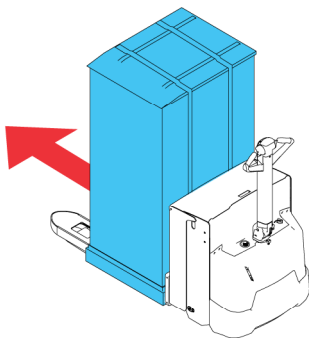

2. Make a visual inspection and examine that there are no signs of shipping damages. Examine the TipNTell and refer to the instructions next to the indicator on the package. The DropNTell indicator is located on the rear panel of the UPS and can be verified after the next step.

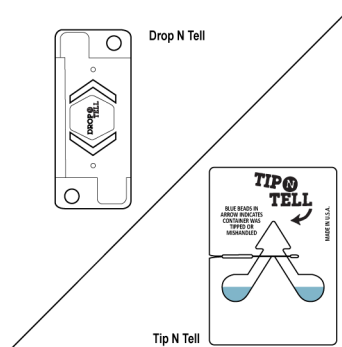

3. Open the UPS package. The roof of the package is used as a ramp for moving the UPS off the pallet.

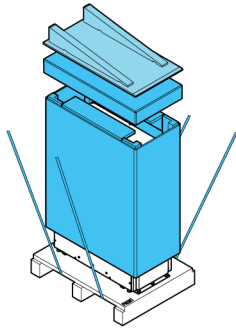

4. Place the ramp on the floor and attach it to the pallet with nails or screws so that it can be safely used for wheeling the UPS off the pallet.

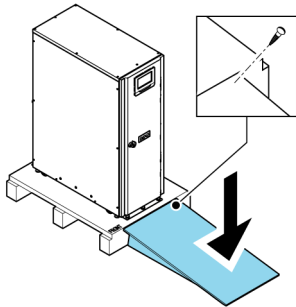

5. If the leveling feet are not fully retracted, turn them until they are retracted.

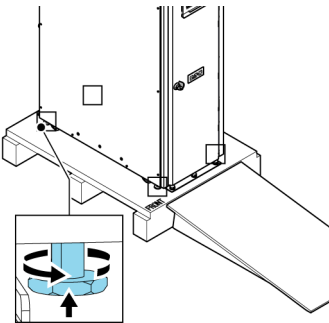

6. Open the UPS front door.

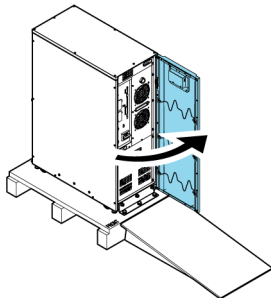

7. Remove the bolts that fasten the shipping brackets to the UPS cabinet and to the pallet.

8. Remove the shipping brackets.

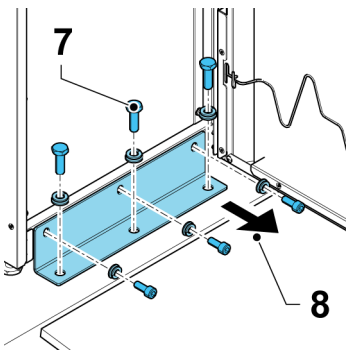

NOTE: After you have removed the shipping brackets, move the unit immediately away from the pallet.

After you have removed the shipping brackets and retracted the leveling feet, do not use a forklift to move the unit while it is still on the pallet. Note that the UPS cabinet is heavy and there are casters under the cabinet.

9. Slowly roll the cabinet toward the ramp edge. Be careful not to push the cabinet too much or too fast since it may cause the cabinet to tip over. Note that the cabinet is heavy. Make sure that you have enough manpower to handle and support the unit while rolling it off the pallet.

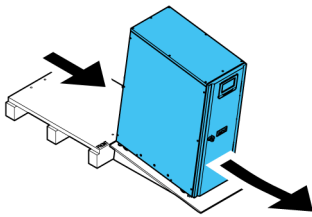

10. Roll the cabinet to its final installation location.

11. To secure the UPS cabinet in position, lower the leveling feet until the cabinet is not resting on the casters and the cabinet is level. With 91PS/93PS 8-10 kW UPS, reattach the shipping brackets to the UPS cabinet to provide extra support. There are 2 options for positioning the shipping brackets: on both sides of the unit or on the front and rear of the unit.

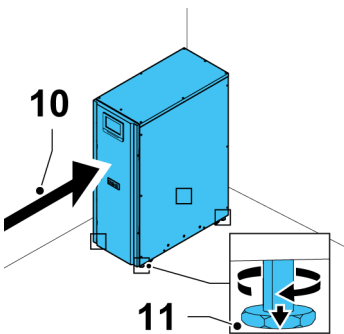

NOTE: If you remove the cabinet from its original installation location and transfer it to a new location on a pallet, lower the leveling feet until the cabinet is not resting on the casters. In addition, attach the shipping brackets to the cabinet and the pallet.

5 UPS system installation

5.1 Introduction to UPS system installation

The operator has to supply the wiring to connect the UPS to the local power source. The installation of the UPS must be made by a locally qualified electrician. The electrical installation procedure is described in the following section. The installation inspection and the initial start-up of the UPS and installing an extra battery cabinet must be carried out by an authorized Eaton Field Service Engineer or by other qualified service personnel authorized by Eaton.



CAUTION

To avoid physical injury or death, or damage to the UPS or the load equipment, follow these instructions during the UPS system installation.



CAUTION

In case of condensed moisture inside the UPS cabinet, dry the cabinet with a blower before starting up the system.

5.2 Steps to install the UPS

Power and control wiring are routed through the rear of the cabinet with connections made to easily accessible terminals, see *Figure 12: Gland plate and connector locations*.

To install and connect the power cabling of the external battery to the UPS, see *Section 5.5 Battery system installation*.

Figure 12. Gland plate and connector locations

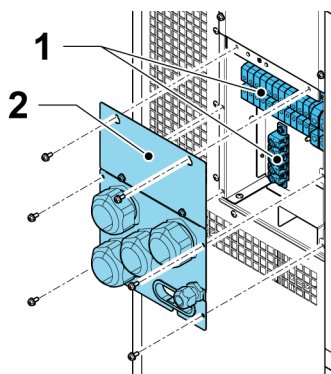

1. Connectors

2. Gland plate

1. To gain access to the terminal blocks, remove the screws securing the gland plate at the back of the UPS.

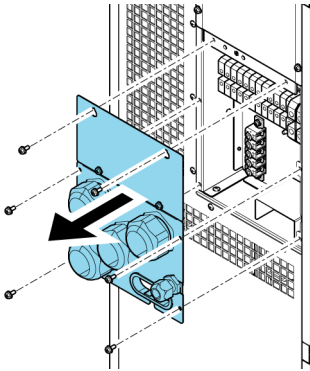

2. If needed, install the additional single feed kit. In 93PS, connect 4 wires. In 91PS, connect 1 wire. For more information, see *Section 5.3 91PS/93PS 8-10 kW UPS Single feed installation*.

Warning: Do NOT apply single feed installation to 3:1 units.

93PS:

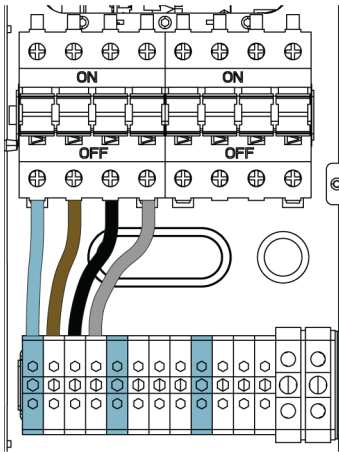

91PS:

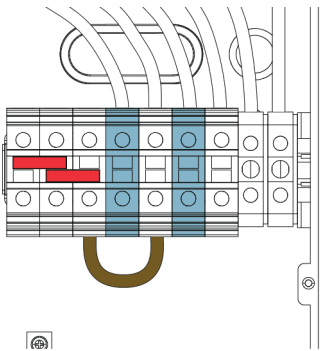

3. If needed, perform field configuration of 91PS from 3:1 to 1:1.

NOTE: Make sure that the jumpers are properly inserted. Mounting the jumpers may require some force.

For more information, refer to *Section 5.4 91PS input system field configuration*.

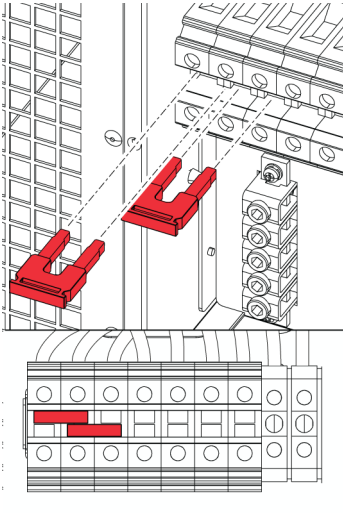

4. Install suitable cable glands into the gland plate.

5. Route the cables through the glands.

6. Connect the cables to the respective terminal blocks, see *Figures 10: UPS power cable terminals for three-phase units* and *11: UPS power cable terminals for single phase units*.

7. Connect the communication cables to the respective terminals and peripherals. For detailed information, see *Figure 23: Communication interfaces in the 91PS/93PS UPS 8-10 kW frame* and *Sections 5.7 Installing a remote EPO switch* and *5.8 Installing interface connections*.

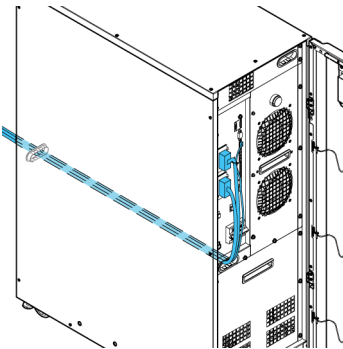

8. Assemble the internal batteries into the battery trays. Connect the battery blocks in series within the battery tray. Only use cables specified by Eaton.

9. Slide the internal battery trays into place and mount the locking brackets.

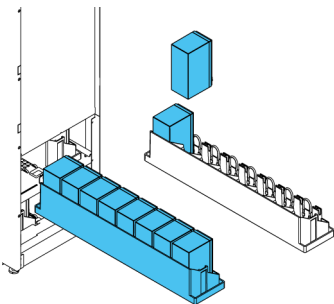

10. Connect the internal batteries.

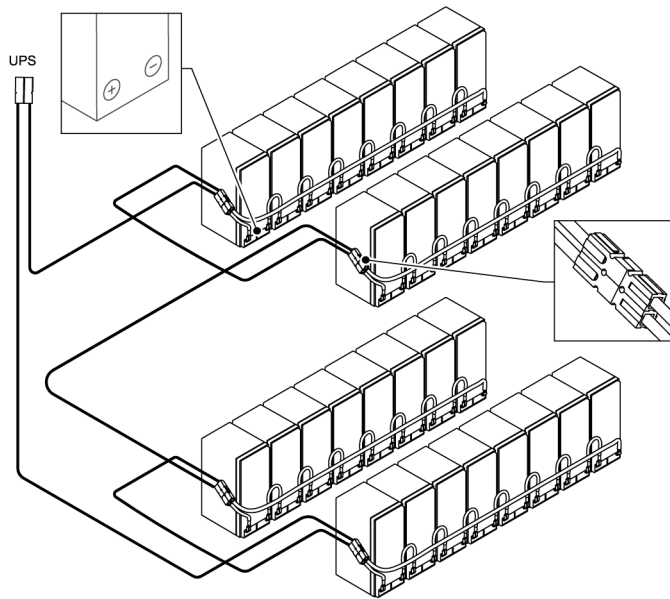

5.3 91PS/93PS 8-10 kW UPS Single feed installation

Additional single feed kits are available for the 93PS (3-phase in / 3-phase out) and 91PS 1:1 (1-phase in / 1-phase out) units. Single feed kits are included in the UPS package.



WARNING

Do NOT apply single feed installation to 3:1 units.

5.4 91PS input system field configuration

If supported by the UPS, the input power system may be configured during the installation of the unit. By default, the 91PS units are shipped with configuration for 3 phase rectifier operation. To change the rectifier input to 1 phase operation, follow these steps:

1. Make sure that the UPS is turned off and all the AC and DC power sources are disconnected.

2. Install the jumpers to the connectors X1:L1 – X1:L3.

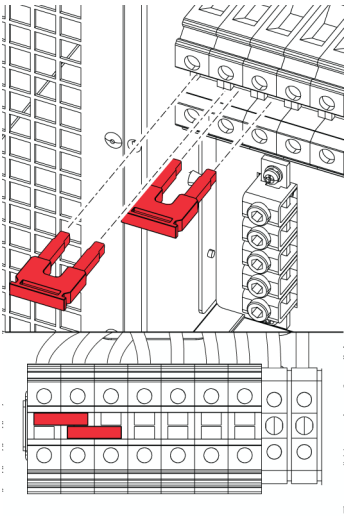

NOTE: Make sure that the jumpers are properly inserted. Mounting the jumpers may require some force.

3. Turn the rectifier feeder circuit breaker and rectifier input switch RIS to the ON position. The UPS display will wake up.
4. On the UPS display, navigate to **Settings** → **Configuration**. You must sign in with Level 2 password.

- On page 2 of the configuration menu, select **Input System Type**.

Figure 13. Page 2 of the configuration menu

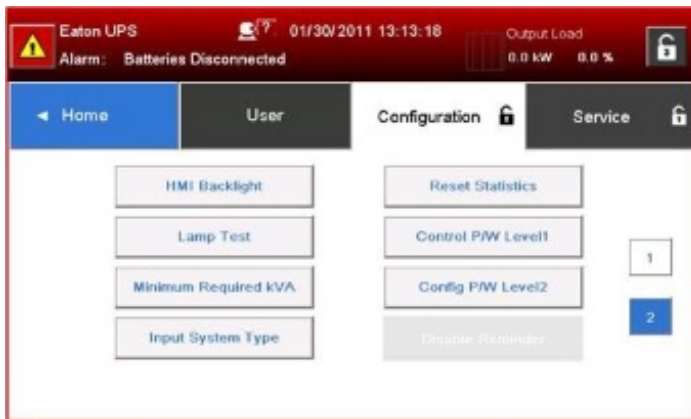

- Select **1PH IN / 1PH OUT**.

Figure 14. Input System Type window



- Select **Save** to save the changes.
The UPS now functions with single phase input.

5.5 Battery system installation



DANGER

This UPS may have internal batteries. The batteries are designed to deliver a large amount of energy and an incorrect connection may lead to a short circuit and cause serious injuries to the personnel or damages to the equipment. In order to avoid damages to the equipment or injuries to personnel, only commissioning personnel are allowed to perform the connection of these batteries.

If you are installing a customer-supplied battery system, install the battery system according to the battery and battery system manufacturer’s instructions and all the applicable national codes and regulations. Only qualified personnel may install the battery system. Battery cables must be protected against current and thermal overload, that is, the battery system must include proper fuses or breaker with protection function. Ground the external battery cabinet to the UPS.

The default battery settings of the UPS are for 12 V VRLA batteries. If you need to use any other type of batteries, contact your Eaton representative. For the battery specification, see *Section 9.6 Battery specification*.

5.5.1 Battery trip wiring

The 91PS/93PS 8-10 kW UPS units are always equipped with an internal battery breaker, which affects only the UPS internal batteries (including the battery sidecar). The external battery breaker is a crucial part of the external battery cabinet or rack and must be placed in it. With the external battery breaker, signal cabling is important.

Both internal and external battery breakers can be tripped (switched off) by energizing its shunt trip coil. The shunt trip coils of external battery breakers are energized (controlled) through connector TB20. The default voltage of the shunt trip coil is 24 Vdc.

Figure 15. Battery trip wiring, TB20

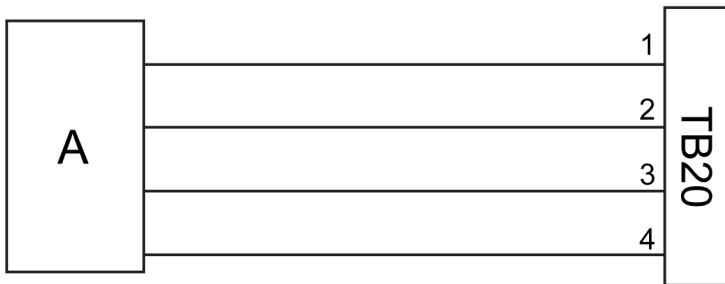

A	External battery breaker	3	Pin 3, AUX contact
1	Pin 1, shunt trip coil +	4	Pin 4, AUX contact return
2	Pin 2, shunt trip coil –		

5.6 Installing additional batteries and battery power cabling

The battery runtime can be extended with an optional sidecar cabinet and/or external battery cabinet(s).

Figure 16. 91PS/93PS 8-10 kW UPS with an additional battery cabinet/a sidecar cabinet on the left

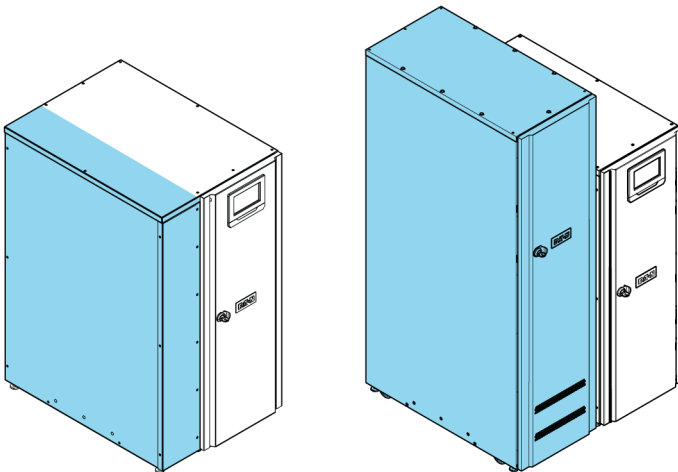

NOTE: Do not connect battery strings with different battery quantity and voltage in parallel.

Power and control wiring for the additional battery assemblies is supplied with the cabinets. The external battery cabinet can be located freely of the 91PS/93PS UPS cabinet. The wiring goes through the back wall of the UPS cabinet.

For instructions on how to install these options, see the instruction manual provided in the package. Earth the external battery cabinet / customer-supplied battery system to the PE terminal 16 shown in *Figure 10: UPS power cable terminals for three-phase units*.

NOTE: If batteries are wired outside the cabinets, follow the installation instructions given in *Section 4.4.3 UPS system power wiring preparations*. See *Tables 10: Minimum recommended multi-core cable and fuse sizes for rectifier and bypass input and UPS output cables (3 phase input, 3 phase output models)* and *11: Minimum recommended multi-core cable and fuse sizes for rectifier input, bypass input and UPS output cables (3 phase input, 1 phase output)* for the recommended cable and fuse sizes.

5.7 Installing a remote EPO switch

A remote EPO switch can be used in case of an emergency to shut down the UPS and remove power to the critical load from a location away from where the UPS is installed.

EPO is connected to the UPS's top front panel, on connector EPO. *Figure 17: Connections of the EPO switch* shows the NO and NC connections of the EPO switch.

EPO connector (front view):

Figure 17. Connections of the EPO switch

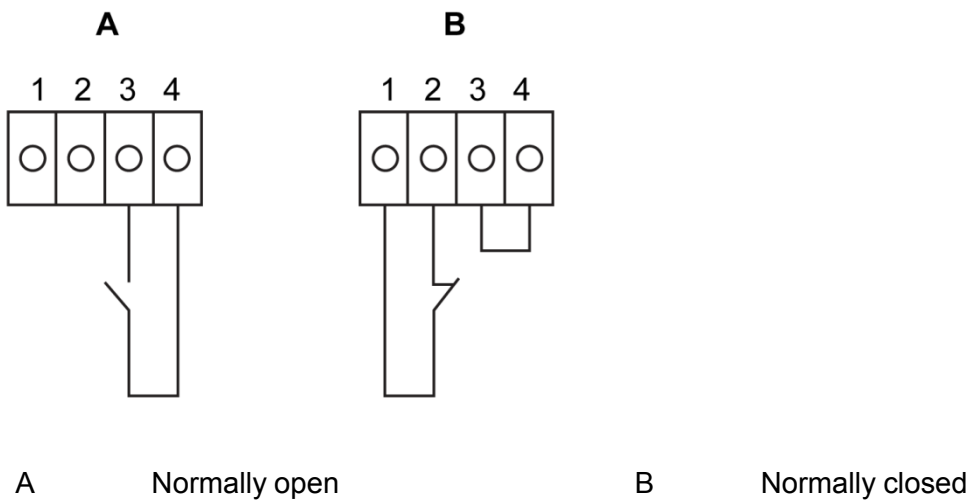

Table 18. Remote EPO wire terminations

From remote EPO switch	To user interface terminal block EPO in UPS cabinet	Remarks
NO	3–4	
NC	1–2	Wire jumper between 3–4 must be installed for proper functions

5.8 Installing interface connections

91PS/93PS UPS contains a total of 5 signal input connectors for operators which can be used for giving remote control commands to the UPS. User interface connector TB1 can be used for these purposes. Each input is a dry relay contact input and requires two-wire signaling. None of the inputs are pre-programmed but need to be separately programmed by qualified service personnel.

When using an external battery system (either the original 91PS/93PS battery cabinet or a customer-sourced battery cabinet/rack), external signaling wiring is recommended to be connected.

One general alarm relay output is also on the front panel. This output is either normally open (NO) or normally closed (NC). The polarity selection is made with a wiring connection. By default, the general alarm relay activates when a system alarm is active, that is, any ALARM condition is active in the system. Alternatively, it can be activated with any particular event, but this must be programmed separately by qualified service personnel. The alarm relay is designed for signal level (ELV or SELV) voltages only, not for utility use. For higher signaling circuit voltage requirements, please use an industrial relay adapter in the MiniSlot.

5.8.1 Installing customer input signals interface

These inputs are located behind the UPS door, in the top section of the UPS. See *Figure 23: Communication interfaces in the 91PS/93PS UPS 8-10 kW frame* for the connector locations.

Tie points with strain relief for the communication cables are located on the right and left side of the cable conduit.

Signal inputs can be configured to different functions. Normally these functions are either informative (for example, “On Generator”) or functional (for example, a remote “Go to bypass” command).

5.8.2 Battery breaker wiring interface

When using the original accessory battery cabinet from the manufacturer, the battery breaker interface wiring is provided with the cabinet. Connecting it requires only routing the wires from the cabinet to terminal TB20.

When using a third-party battery system, the breaker must be equipped with auxiliary signal and should have a 24 V shunt trip for remote opening of the breaker, when needed.

Wire entry for the battery breaker signal wiring is located in the middle of the UPS cabinet. Punch holes are located on the left or right side panel, back wall or bottom plate.

See *Section 5.5.1 Battery trip wiring* for installation instructions.

5.8.3 Relay output interface connections

The general alarm relay is a dry relay signal output. The relay can be used for informing the operators about UPS alarm conditions, for example through a building management system. By default, the relay is configured to activate when the UPS general alarm is active, that is, any event when the ALARM status is active. The relay can also be configured to activate by some other event, but this needs to be done by authorized service personnel.

Relay signal wiring can be installed only through the signal cabling canal, from back to front, in the top section of the UPS.

Additional relay outputs are available with mini-slot cards. Relay outputs can be configured to be activated by various events. Configuration can be done by an authorized Eaton Field Service Engineer or by other qualified service personnel authorized by Eaton.

5.8.4 Industrial Relay Card interface connections

Relays K1 through K5 are identical in function. Each output contact function can be assigned by the user. The UPS information may also be configurable.

To install the INDRELAY-MS:

1. Examine that the ancillary equipment system is turned off and all the power sources are removed. Refer to the appropriate operation manual of any ancillary equipment for shutdown instructions.
2. Install wiring from the IRC to the monitoring equipment using appropriate conduits through the cable exit opening in the IRC.
3. Connect wiring between the IRC terminal blocks and the monitoring equipment using terminations. Connect one wire to COM (Common) and another to either NC or NO to select the Normally Open or Normally Closed option.
4. Install the INDRELAY-MS into an open MiniSlot communication bay in the UPS cabinet.

Figure 18. Industrial Relay Card INDRELAY-MS

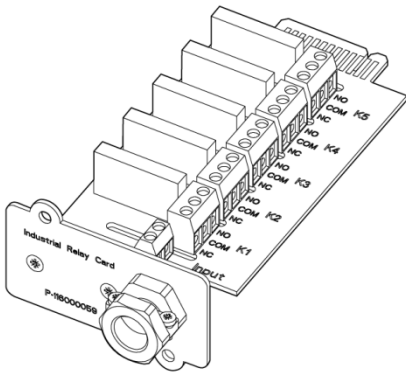

5.8.5 Minislot interface connections

For MiniSlot accessories and communication devices selection, see *Chapter 6.1 Introduction to communication interfaces*. For installation and setup of a MiniSlot card, please contact your Eaton representative.

To install wiring to the connections:

1. If not already installed, install the LAN drops.
2. Open the front door of the UPS.
3. To remove the MiniSlot cover plate, remove the 2 screws securing the plate.
4. To install the MiniSlot communication device, push it all the way in.
5. Secure the MiniSlot communication device with 2 screws.
6. Route and install the LAN and other cables to the appropriate MiniSlot cards. The cable route is through the signal cable canal in the top section of the UPS.
7. For operator instructions, refer to the manual supplied with the MiniSlot card.
8. When all the wiring is completed, close the front door and secure it with the latch.

5.8.6 Installing signal interface connections in a parallel system

The installation of the signal interface connections in a parallel system is done by following the aforementioned instructions. Signal inputs can be paralleled between the units, that is, the same contact can be used for several units' signal input signaling. This concerns also the EPO signal.

5.9 Wiring parallel 91PS/93PS UPS systems

The outputs of multiple 91PS/93PS UPS systems can be connected in parallel. Up to 4 units can be paralleled. The UPS static bypass power rating needs to be identical among all the paralleled units. However, paralleled UPS cabinets can be housed with different number of UPM power modules.

The outputs are paralleled to increase the load capacity of the power system and for redundancy. The system is paralleled for (N+1) redundancy as long as there is always one or more UPS online than required to support the load. The system is paralleled for capacity if all UPSs in a system are required to support the load.

Communication between the UPSs is required for system metering and mode control. The system level communication and control are accomplished using a Controller Area Network (CAN). A pull-chain signal in each UPS, connected to the other UPSs in parallel and tied to the bypass status relay in each UPS, is

used for a secondary communication path. This arrangement ensures bypass control even if the CAN bus is lost.



WARNING

Do not use the internal maintenance bypass switch in units that are connected in a parallel configuration.

5.9.1 Power wiring overview

See *Section 4.4.3 UPS system power wiring preparations* for the recommended cable and external fuse sizes and installation practices.

Input feed

The input feed is defined as the power source connected to the UPS rectifier. The feed to all UPS's inputs must be derived from the same source.

Bypass feed

The bypass feed is defined as the power source connected to the UPS bypass. The feed to all UPS's bypass must be derived from the same source. The shortest length of power wire from the source to the UPS must be a minimum of 95% of the length of the longest wire.

Output

The neutrals of all the UPSs must be connected. The shortest length of wire from the source to the UPS must be a minimum of 95% of the length of the longest wire. The measurement is with respect to where the UPS's outputs are tied.

Dual source

The input feed and bypass feed may be separate sources. The sources must share a common neutral.

Battery connection

A separate battery shall be connected to each UPS, and the battery capacity for each UPS must be identical. A common battery for all UPSs is not supported.

MOBs

Module Output Breakers (MOBs) allow the output of an UPS to be disconnected from other UPSs and the system load for maintenance and service. Design considerations assume that each UPS has a Module Output Breaker (MOB). The breaker should also disconnect the neutral for improved safety during maintenance.

The MOB must have a Form "C" auxiliary contact. The N.C contact is connected to the corresponding UPS's input used for signal input. The N.O. contact is used to disconnect the bypass pull-chain when the MOB is open. *Figure 19: Principle of paralleled UPS systems* shows the principles of paralleled UPS systems including MOBs and outputs from UPSs.

MOB override

Users without MOBs installed can simply leave the MOB signal input disabled. The user should be aware that systems without MOB have limited maintenance capability.

Parallel system cabling

Figure 19. Principle of paralleled UPS systems

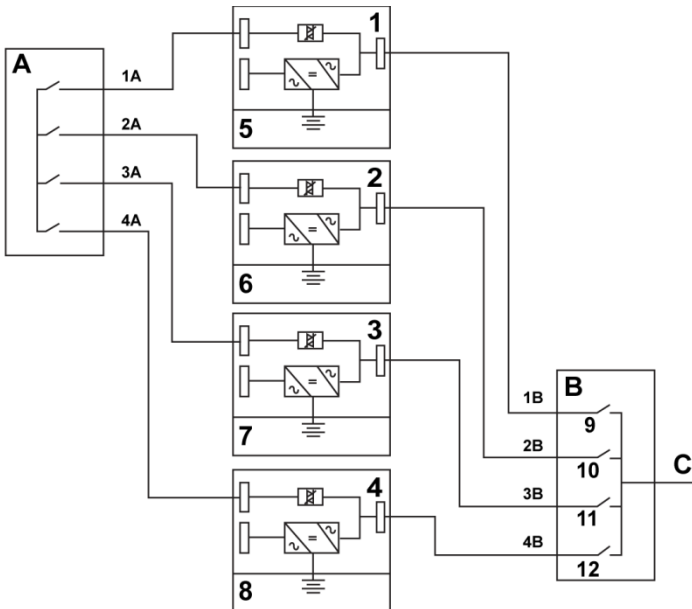

A	Bypass inputs to UPSs	1	UPS 1	7	Battery
B	Outputs from UPSs	2	UPS 2	8	Battery
C	Load	3	UPS 3	9	MOB1
		4	UPS 4	10	MOB2
		5	Battery	11	MOB3
		6	Battery	12	MOB4

The required parallel system wiring length must be equal to ensure approximately equal current sharing when in the bypass mode.

For proper operation, the following must be true: $1A+1B=2A+2B=3A+3B=4A+4B$

Any differences in wire length result in decreased capacity and improper operation of the UPS system while in the bypass mode.

5.9.2 Control signals overview

2 controls signals (External CAN Network, Bypass Pull-Chain) are required for external paralleling. Both of these control signals are fault-tolerant and alarmed when disconnected.

External CAN (ECAN)

ECAN provides means for communication between the UPS's in a parallel system. When this network fails, the system continues to share load and protect the load.

Bypass Pull-Chain

Bypass Pull-Chain is an open collector signal that goes low when the bypass static switch of any UPS is online. When External CAN (ECAN) is down, the pull-chain is low and the UPS is online, the UPS locks to and transfers to the bypass mode. Service can manually short this signal in some rare failure modes to force a system transfer to bypass.

Signal Inputs Actions

Each UPS has a maximum of 7 signal inputs, 5 native and one in each MiniSlot when using a suitable connectivity device. These inputs can be configured with action items. The following action items affect all the UPSs in the system. When an action item is active on a UPS and the MOB is closed, the action item is transmitted on the ECAN to all the UPSs. All the UPSs react in the same manner as if the action item was active on that UPS.

Wiring the EPO switch in parallel

It is recommended to use separate EPO circuits for each parallel unit.

5.9.3 Installing bypass control wiring

1. During the installation, obey all the safety instructions given in this document.
2. Terminal blocks TB2, TB3 and TB4 are for external parallel control signals.
3. The Phoenix Contact FRONT-MSTB 2,5/2-STF-5,08 and 2,6/4-SFT-5,08 plug components are used for cable wiring termination.

Figure 20. Simplified CAN and Pull-Chain wiring for parallel UPS system

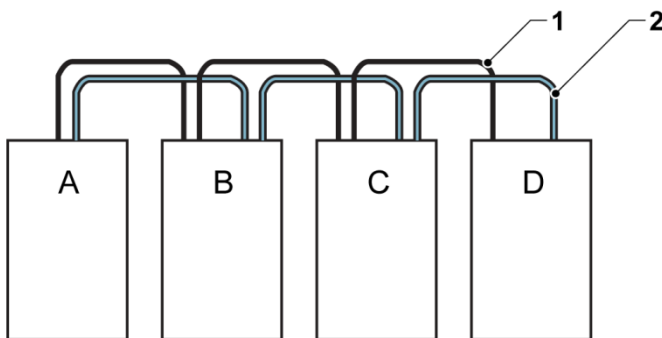

A	UPS 1	1	CAN
B	UPS 2	2	Pull chain
C	UPS 3 (if installed)		
D	UPS 4 (if installed)		

NOTE: This drawing is for distributed bypass wiring purposes and it is not a floor layout plan. UPSs can be placed in any physical order.

Figure 21. CAN and Pull-Chain wiring for parallel UPS with MOBs

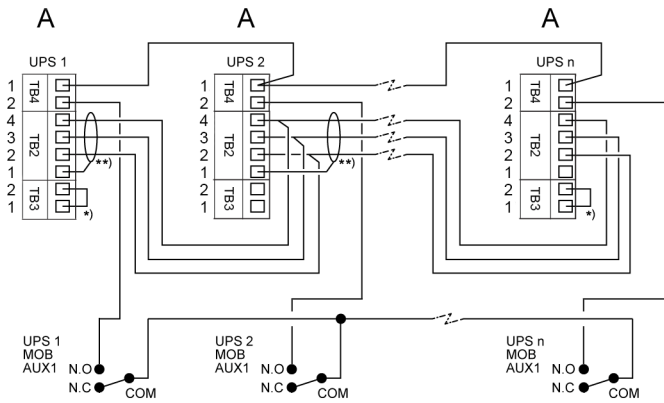
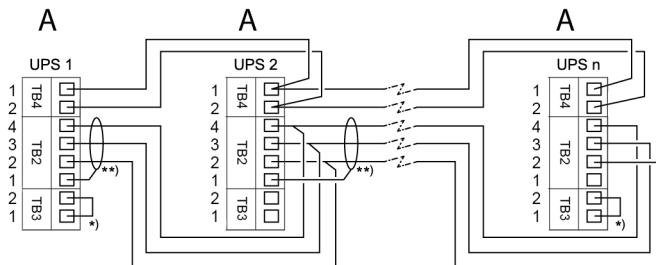

Figure 22. CAN and Pull-Chain wiring for parallel UPS without MOBs



A,B,C	External parallel connectors TB6–TB8	6	TB7:1: Earth
1	TB6:2: Pull chain	7	TB8:1: CAN Termination 2
2	TB6:1: Pull chain RTN	8	TB8:2: CAN Termination 1
3	TB7:4: CAN High	*)	Terminate the first and last UPS with a jumper
4	TB7:3: CAN Low	**)	Connect the shield on one end only
5	TB7:2: CAN GND		

NOTE: NC and NO designations on MOB AUX contacts are defined with the breaker in the OFF (open) position. If the MOB contacts have pigtail leads, use the same wire gauge to connect to the UPS and use the correct crimp connections for the wire gauge. External CAN connections between the UPS cabinets require shielded twisted pair wire. Use twisted pair wiring between the UPS and MOB AUX contacts. Always confirm contact operation prior to wiring.

5.10 UPS system interface wiring preparation

Control wiring for features and options should be connected at the user interface terminal blocks located on top front of the UPS, behind the door.

NOTE: Do not connect relay contacts directly to the mains-related circuits. Reinforced insulation to the mains is required.

When you are planning and performing the installation, make sure you understand the following notes:

- All the interface wiring is provided by the operator.
- When installing internal interface wiring to MiniSlot terminals, route the wiring through the internal opening in the MiniSlot communication bay.
- All signal inputs or remote features require an isolated normally-open contact or switch (rated at 24 VDC, 20 mA minimum) connected between the alarm input and the common terminal. All control wiring and relay and switch contacts are supplied by the operator. Use twisted-pair wires for each alarm input and common.
- The signal inputs can be programmed to display the alarm's functional name.
- LAN drops for use with MiniSlot cards are provided by facility planners or the operator.
- The UPS Battery Aux and 24 VDC Shunt Trip signal wiring from the UPS must be connected to the DC source disconnect device. See *Figure 15: Battery trip wiring, TB20*.
- Battery Aux and 24 VDC Shunt Trip wiring must be a minimum of 1.5 mm².
- The Remote EPO feature opens all switchgear in the UPS cabinet and isolates power from your critical load. Local electrical codes may also require tripping upstream protective devices to the UPS.
- The Remote EPO switch must be a dedicated switch that is not tied to any other circuits.
- If the normally-closed (NC) Remote EPO contact is used, a jumper wire must be connected between pins 1 and 2 on connector EPO.
- Remote EPO wiring should be a minimum of 0.75 mm² and a maximum of 2.5 mm².
- The distance between the Remote EPO and the UPS cannot exceed 150 meters.
- Alarm relay contacts have a maximum current rating of 5 A and a switched voltage rating of 30 VAC (RMS) and 30 VDC.
- Alarm relay wiring must be a minimum of 0.75 mm².

6 Communication interfaces

6.1 Introduction to communication interfaces

This section describes the communication features.



CAUTION

All the communication interfaces are SELV circuits. When connecting to other equipment, make sure that you maintain this characteristic.

The UPS has the following communication interfaces:

1. MiniSlot 1
2. MiniSlot 2
3. USB device (connection to computer)
4. Communication cable conduit
5. Emergency Power Off (EPO)
6. Relay output
7. USB host (connection to accessories)
8. Signal inputs
9. RS-232 port for service

See *Figure 23: Communication interfaces in the 91PS/93PS UPS 8-10 kW frame* for the location of communication interfaces in 91PS/93PS UPS 8–10 kW.

Figure 23. Communication interfaces in the 91PS/93PS UPS 8-10 kW frame

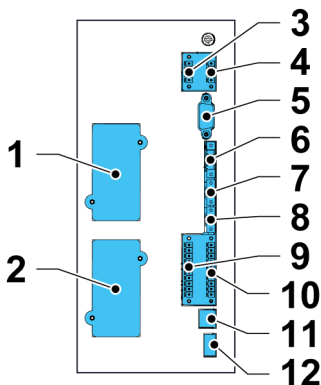

- | | |
|----------------------------------|--|
| 1. MiniSlot 1 | 8. TB4, pull chain bus |
| 2. MiniSlot 2 | 9. TB7, not used |
| 3. TB6, relay output | 10. TB5, signal inputs 1...5 |
| 4. TB1, EPO | 11. USB2, USB device (connection to computer) |
| 5. Serial COM RS-232 | 12. USB1, USB host (connection to accessories) |
| 6. TB2, external CAN | |
| 7. TB3, external CAN termination | |

6.2 MiniSlot cards

The Eaton 91PS/93PS UPS has 2 MiniSlot communication bays. To install a MiniSlot card, obey the instructions in *Section 5.8.5 Minislot interface connections*.

The UPS is compatible with the following MiniSlot cards:

- **Gigabit Network Card (NETWORK-M2)**
Enhances the capabilities and protection provided by the UPS by enabling Web and SNMP based remote monitoring and e-mail alarms. The card also enables shutdown of servers and migration of virtual machines through IPM and IPP software. Supports 10/100 Mbit and Gigabit Ethernet.

Figure 24. Gigabit Network Card

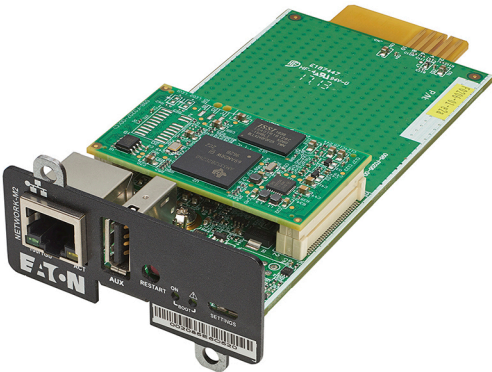

- **Industrial Gateway Card (INDGW-M2)**
This card has all the features and capabilities of the Gigabit Network Card. In addition, it also provides direct integration of system level UPS information (meters and status) to a Building Management System (BMS) using the Modbus RTU and Modbus/TCP.

Figure 25. Industrial Gateway Card

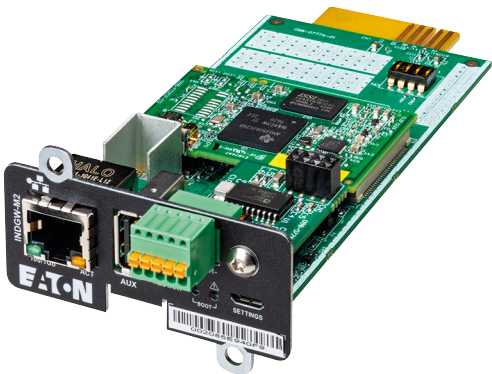

- **PX Gateway Card (only with 93PS (3:3) UPS)**
Provides remote monitoring through a Web browser interface, e-mail, and a network management system (NMS) using SNMP and connects to a twisted-pair Ethernet (10/100BaseT) network. The card also provides direct integration of UPS information (meters and status) to a Building Management System (BMS) using the Modbus RTU and TCP protocols as well as BACnet protocols.

Figure 26. PX Gateway Card



- **Industrial Relay Card-MS**

The MiniSlot Industrial Relay Card provides a way of connecting the 91PS/93PS to industrial and electrical monitoring systems. It also enables a wide range of control applications by allowing up to 250 volts and 8 Amperes through its 5 relay connections. By connecting wires to the corresponding places in its terminal blocks, you can choose Normally Open or Normally Closed setup for each output. For information on how to configure the Industrial Relay Card-MS, see *Section 6.6 Configuring relays*.

Figure 27. Industrial Relay Card-MS

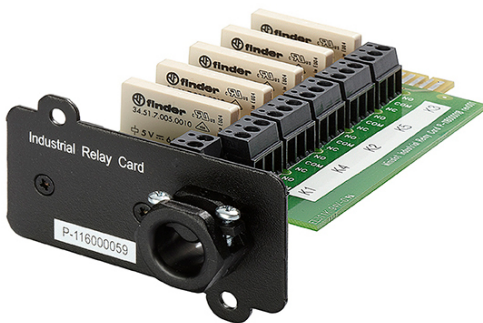

6.3 Intelligent Power Software

Intelligent Power Software are productivity tools for UPS power management. These software solutions enhance the protection provided by a UPS by shutting down applications and operating systems, triggering disaster recovery procedures and migrating virtual machines in case of an extended power outage. They also help in reducing downtime and increasing the reliability of the UPS by alarming the operators of issues and monitoring vital meters. The software can also be used to view the usage characteristics of power equipment across the enterprise and use the data to optimize the use of the facilities.

Intelligent Power Software is web-based, which means that the information can be accessed through any device that has a web browser.

On one hand, Intelligent Power Manager (IPM) is a monitoring system that can concentrate the data and alarms of hundreds of UPS, ePDU and other devices into a single view. On the other hand, it provides a link to virtualization through management systems, such as VMware vCenter. This way an administrator gets a single pane of glass to manage both IT equipment and the supporting infrastructure. IPM provides the shutdown, migration, disaster recovery and load shedding features in virtualized environments.

Intelligent Power Protector (IPP) is a shutdown agent with basic monitoring and alarming capability. It provides automatic, graceful shutdown of computers and virtual machines or servers powered by an Eaton UPS during a power outage that lasts longer than your available battery runtime. Intelligent Power Protector can be remotely supervised and managed by the Intelligent Power Manager (IPM) application.

Intelligent Power Software is delivered on a CD with the UPS. Alternatively, you can download it from the Eaton web page. Some of the advanced features of IPM require a license, contact your Eaton representative for details.

6.4 Signal input monitoring

This standard feature lets you connect smoke detectors or over-temperature alarms to your signal inputs. The user interface terminals for external connections are located inside the UPS. Use twisted-pair wires for each alarm input and common.

The signal inputs can be programmed to display the alarm functional name.

6.5 General purpose relay contact

One general purpose relay contact is provided as a standard feature on the UPS. An alarm contact is also provided.

You can use a normally-closed or normally-open contact. If the state of the contact changes from the state you specify as normal, a signal is issued. You can connect this contact to equipment at your facility (such as a light or an alarm bell) to let you know when an alarm is active on the UPS. This feature is useful if the UPS is located in a remote area where the UPS horn may not be heard immediately.

NOTE: Do not operate the contacts in excess of 30 VAC (RMS) and 30 VDC at 5 A maximum.

6.6 Configuring relays

91PS/93PS offers one native relay output. Additionally, each of the 2 MiniSlots can be equipped with a relay card, including 5 relays. The following instructions guide you through the relay configuration.

Currently the relay configuration can be done only using the display. The service tool does not yet have support for nodebit functions.

The maximum voltage of the relay is 30 V. Examine the voltage and current specifications of the other cards from the previous sections.

The process for relay configuration is as follows:

1. In the home screen of the display, click the lock icon in the top right corner to type in the service password.

2. In the sign in window, click the password field containing the 4 dots.

Figure 28. Sign in window with the password field

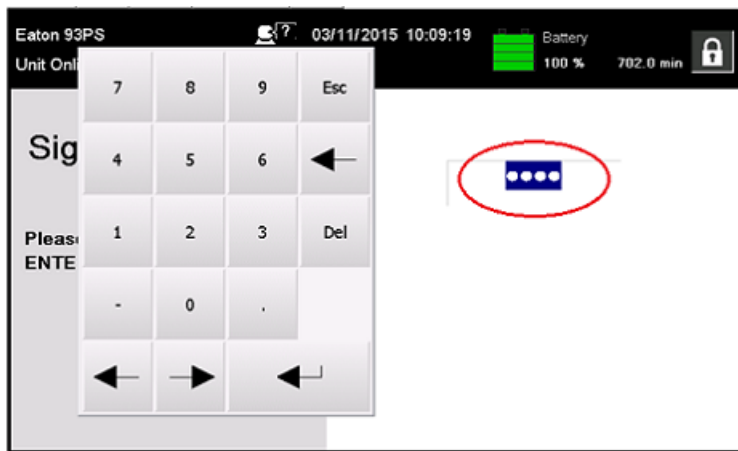

3. Enter the password 0101 and press <ENTER>.
4. Select **Continue**.

5. Select **Configuration** and then **Relays Outputs**.

Figure 29. Selecting Relay Outputs in the Configurations screen

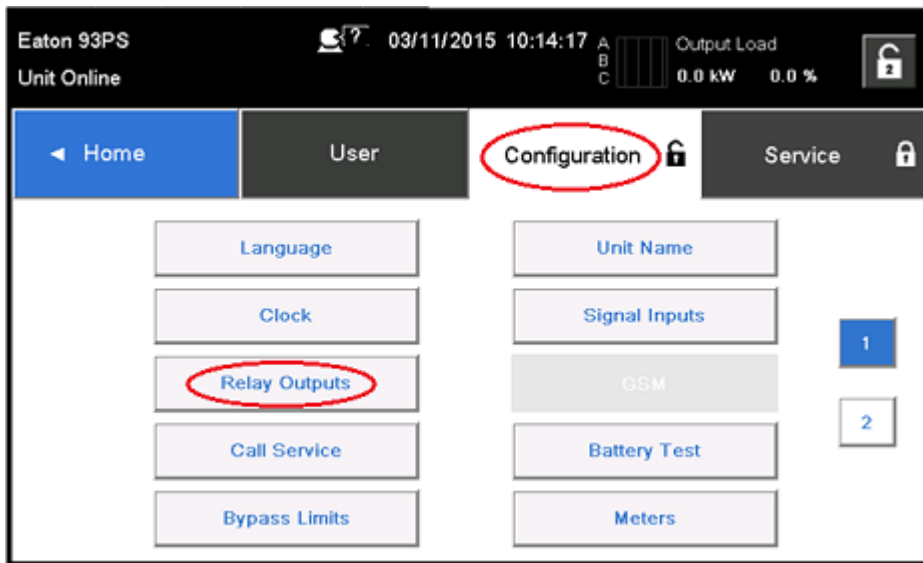

6. Select out of the following options:

- Native (Alarm) relay
It is possible to set 8 different events for the native relay. If any of the set events occurs, the relay is activated.
- MiniSlot 1
- MiniSlot 2

Figure 30. Options for relay outputs configuration

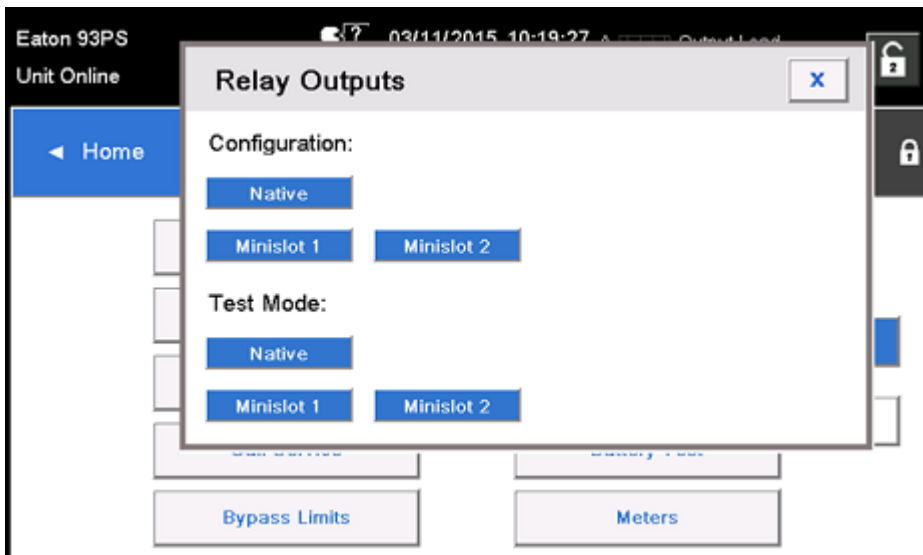

7. Enter the code(s) of the function(s) that you want to trigger the relay when they become active.

8. Press **OK** and Save to save the changes.

Figure 31. Entering the codes of the functions that will trigger the relay

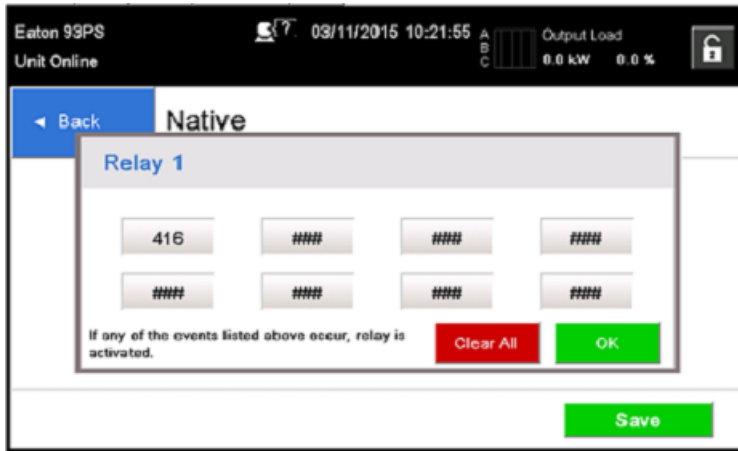

9. If you selected one of the MiniSlots, the following default values are available:

- Relay 1: #58 On Line (LED is lit)
- Relay 2: #38 On Battery (LED is lit)
- Relay 3: #224 Alarm (LED is lit)
- Relay 4: #39 On Bypass (LED is lit)
- Relay 5: #15 and #21 Low Battery warning

Alternatively, you can configure the relays with any event you want.

10. You can test the relays by selecting any of the options in the test mode (see *Figure 32: Relays*).

Figure 32. Relays

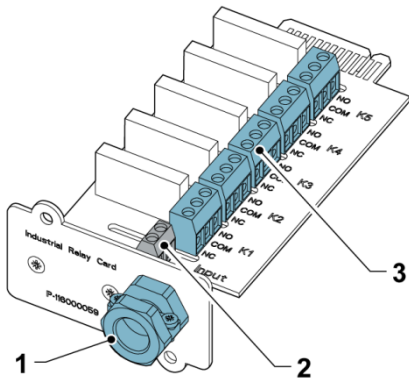

1. Cable exit opening for up to 12 mm (1/2") conduit
2. Signal input connector with voltage supply
3. K1 thru K5 terminal connections for relay contacts to operator's monitoring equipment

7 UPS operating instructions

7.1 Introduction to UPS operating instructions

This section describes how to operate the UPS.



CAUTION

Before you operate the UPS, make sure that all the installation tasks are completed and a preliminary startup has been performed by authorized service personnel. The preliminary startup verifies all the electrical interconnections to make sure that the installation was successful and the system operates properly.

Before you operate any of the controls, read these instructions and have a thorough understanding of the UPS operation.

The UPS is configured to operate with one of the following nominal voltages: 380, 400, or 415 VAC. Before you start to operate the UPS, confirm the UPS nominal voltage and frequency from the display by selecting Settings > Information. If the UPS need to be operated with another voltage or frequency, contact your closest Eaton office or Eaton authorized partner.

NOTE: The UPS is not a measuring device. All the displayed measurements are approximate values only.

7.2 UPS controls and indicators

7.2.1 Control panel

The control panel, located on the UPS front door under a protective hatch door, contains a color touch screen display. It is used to display the status of the UPS system and control the operation of the UPS.

Figure 33. Parts of the display

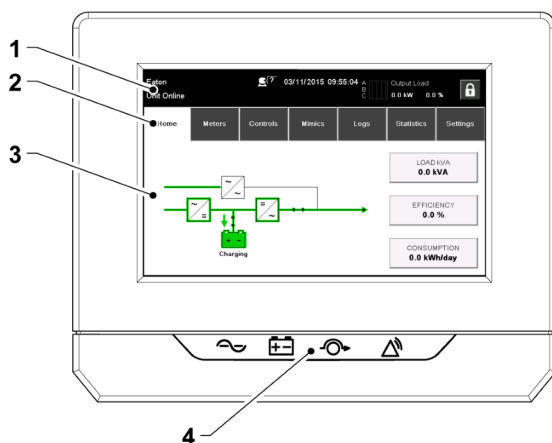





The display consists of the following parts:

1. Status bar. The status bar displays the UPS name, state, current date and time, meters information, and a sign in/out button. It also shows any active alarms and warnings.
2. Main navigation. Select a screen by tapping on its name.
3. Content area. This is the main area for showing information on the UPS status and operations.
4. Status indicators. See *Section 7.2.2 Status indicators*.

7.2.2 Status indicators

The four symbols below the display are status indicators. They are colored light emitting diode (LED) lamps, and they work in conjunction with the alarm horn to let you know the operating status of the UPS.

Table 19. Status indicators

Indicator	Status	Description
 Green symbol for normal operation	On	The UPS is operating normally and supplying power to the critical load.
	Off	The UPS is turned off.
 Yellow symbol for battery mode	On	The UPS is in the battery mode. Because the battery mode is a normal condition of the UPS, the green indicator for normal operation also remains illuminated.
 Yellow symbol for bypass mode	On	The UPS is in the bypass mode. The critical load is supported by the bypass source. The green indicator for normal operation is not illuminated when the system is in the bypass mode.
 Red symbol for active alarm	On	The UPS has an active alarm and requires immediate attention. The screen shows the highest priority active alarms. All alarms are accompanied by an audible horn. To silence the horn, press any control panel button once. The alarm indicator may be illuminated along with other indicators.

7.2.3 System events

When the UPS system is running in the double conversion mode, it continually monitors itself and the incoming utility power. In the battery or bypass mode, the UPS may issue alarms to let you know exactly what event caused the change from the double conversion mode. System events on the UPS can be indicated by horns, lights, messages, or all three.

Select Logs in the home screen to look at any currently active events.

- **System event horn**
The system event horn beeps to alert the user that an event requiring attention is taking place.
- **System event indicators**
The status indicators on the UPS control panel and the event horn let you know when the UPS system is operating in any mode other than the double conversion mode. Only the green indicator for normal operation is visible during normal UPS system operation. The other indicators illuminate to indicate alarms or events. When an alarm occurs, first examine these indicators to see what type of event has taken place.
- **System event messages**

When a system event occurs, a message appears in the status bar of the display. This message is also written to the Active Events log. Some notices and alarms may be accompanied by an audible horn. To silence the horn, press any button once.

7.2.4 Menu structure of the 91PS/93PS UPS

The following table shows the menu structure of the 91PS/93PS UPS.

Table 20. Menu structure of the 91PS/93PS UPS

Main menu	Submenu	Functions
Home	-	An overview of the UPS operation, including information on load, efficiency and consumption.
Meters	Meters summary	A summary of the UPS or system meters.
	Input meters	Detailed information on UPS or system input meters.
	Bypass meters	Detailed information on UPS or system bypass meters.
	Output meters	Detailed information on UPS or system output meters. UPM Power
	Battery meters	Detailed information on UPS or system battery meters.
Controls	System controls	Go to bypass Go Online Load Off
	UPS controls	Turn Off Charger Run battery test Shut down UPS
	EAA controls	ESS: • Enable • Disable ABM: • Enable • Disable • Configure Clear logs Clear status Clear alarms
Mimics	UPS mimics	An overview of the UPS operation, including information on load, efficiency and consumption. If there is an error, an error indicator is displayed next to the affected part. Active events log can be opened by tapping the error indicator.

	System overview	System overview shows the status and meters summary for each UPS.
	ESS	The ESS mimic screen shows the approximated consumption and energy savings of the ESS mode.
Logs	Active events	All active events are displayed.
	System log	A log of all system events.
	Service log	A detailed log of UPS operations.
	Change log	A log of all changed settings and their values.
Statistics	UPS	A summary of UPS statistics
	Battery	Details are not available.
Settings	User Configuration Service	Configurable user settings.

7.2.4.1 User settings

The UPS includes information for the user. You can modify the **User** settings. In the Home screen, select **Settings**.

Table 21. User settings

Setting	Description
Information	Information on the UPS model, including part number and serial number.
About	Version information.

You need to sign in to modify the **Configuration** settings.

Table 22. Configuration settings

Setting	Description
Language	Change the user interface language.
Unit Name	Change the unit name.
Clock	Change the date and time, change the clock format or enable/disable NTP clock setup.
GSM	GSM modem.
Call Service	Send automatic e-mail to the service center in case of a failure.
Signal Input	Select signal input name and function or change contact polarity.
Relay Outputs	Configure the relay outputs.
Battery test	Change the power level and duration for battery test.

Setting	Description
Bypass Limits	Change the bypass voltage or bypass frequency.
Screen Saver Timeout	Change the screen saver timeout.
Meters	Change the meters format.
Lamp Test	Enable the lamp test.
HMI backlight	Adjust the backlight brightness.
Control P/W level 1	Change the level 1 password, or remove the password on level 1. The default value is 1111.
Control P/W level 2	Change the level 2 password. The default value is 1010.
Reset statistics	Reset all statistics.
Minimum required kVa	Change the minimum required kVa.

7.3 Signing in

If the level 1 password is enabled, you need to sign in.

1. Press the lock icon in the top right corner of the screen.
2. Type in your password and press **OK**.
You are signed in.
3. Press **Continue** to return to the previous screen.

You have 3 attempts to type in the password. If an incorrect password is given more than 3 times, you need to wait for 30 minutes before trying again.

To modify the user settings, you need to enter the level 2 password. For the default passwords, see *Section 7.2.4.1 User settings*.

7.4 System control instructions

7.4.1 Starting the UPS system in the double conversion mode

The UPS system can consist of a single UPS or several parallel UPSs. UPSs with their MOB open are not considered as part of the system.

To start the UPS system:

1. Make sure that the UPS input and bypass (if dual feed) feeder circuit breakers are in the ON position.
2. Turn the mains switch RIS and the bypass switch BIS (if installed) to the ON position.
3. Open the UPS front door.

4. Turn the battery breaker CB1 to the ON position. Make sure that the breakers in the external battery cabinets are ON.
5. Make sure that there are no active alarms on display.
6. In the home screen, press **Controls**.
The System controls screen appears.
7. Select UPS controls (Single UPS) or System controls (UPS system).
8. Press the **GO online** button. Confirm **GO online**.

The UPS system is now operating in the double conversion mode. The green status indicator for normal operation is lit in all the UPSs in the system.

7.4.2 Starting the UPS system in the bypass mode



CAUTION

In the bypass mode, the critical load is not protected from mains power interruptions and abnormalities.

If the inverter output of the UPS is not available and the critical load needs to be energized, perform the following procedure:

1. Make sure that the UPS input and bypass (if dual feed) feeder circuit breakers are in the ON position.
2. In the home screen, press **Controls**.
3. Select **System controls**.
4. In the System controls screen, press the **Go to bypass** button.
Confirm your selection.

The UPS system is now operating in the bypass mode. The yellow bypass status LED indicator is lit.

7.4.3 Transferring from the double conversion mode to the bypass mode



CAUTION

In the bypass mode, the critical load is not protected from mains power interruptions and abnormalities.

To transfer the critical load to the bypass mode, perform the following procedure:

1. In the home screen, press **Controls**.
The System controls screen appears.
2. In the System controls screen, press the **Go to bypass** button. Confirm your selection.
The UPS system transfers to the bypass mode and the critical load is immediately supplied by the bypass source. If the bypass source is not available, the power processor remains on and an alarm sounds.

NOTE: If bypass is not connected, it is greyed out. In this case there is no alarm sound.

The UPS system is now operating in the bypass mode and the yellow bypass status indicator is lit. The status is shown as **UPS On Bypass**.

7.4.4 Transferring from the bypass mode to the double conversion mode

To transfer the critical load to the double conversion mode, do the following procedure:

1. In the home screen, press **Controls**.
2. Select **UPS controls** (Single UPS) or **System controls** (UPS system).
3. Press the **Go online** button. Confirm your selection.
The UPS system transfers to the double conversion mode. If there is not enough UPM capacity available, the system remains in the bypass mode and an alarm sounds.

The UPS is now operating in the double conversion mode. The green status indicator LED for normal operation is lit.

7.4.5 Transferring from the double conversion mode to the Energy Saver System mode

NOTE: Note that the Energy Saver System mode commands are displayed only if enabled at the factory or by an authorized Eaton Field Service Engineer.

To transfer the critical load to the Energy Saver System mode:

1. In the home screen, press **Controls**.
2. Select **EAA controls**.
3. Select **Enable ESS**.
The entire UPS system transfers to the Energy Saver System mode and the critical load is supplied by the bypass source. If the bypass source is not available or the conditions are not correct for the ESS mode, the power module remains on. The green status indicator for normal operation is illuminated. The UPS status is shown as `UNIT ONLINE, ESS`. In the System Log, the UPM status is shown as `ESS Mode On`.

7.4.6 Transferring from the Energy Saver System mode to the double conversion mode

NOTE: Note that the Energy Saver System mode commands are displayed only if enabled at the factory or by an authorized Eaton Field Service Engineer.

To transfer the critical load to the double conversion mode:

1. In the home screen, press **Controls**.
2. Select **EAA controls**.
3. Select **Disable ESS**.
The UPS system transfers to the battery mode and then to the double conversion mode. If the power module is not available, the system remains in the bypass mode and an alarm sounds. The green status indicator for normal operation is illuminated. The UPS status is shown as `UNIT ONLINE`. The UPM status is shown as `ACTIVE`.

7.4.7 Shutting down the UPS system and critical load

To perform maintenance or service on the critical load, shut down the power to the load:

1. Turn off all the equipment that is powered by the UPS system.
2. Select **Controls** on the home screen.
3. Select **UPS controls** (Single UPS) or **System controls** (UPS system).
4. Press the **Shut Down System** or **Shut Down UPS** from System controls or UPS controls menu bar.
5. Confirm the shut down.
6. Turn the UPS input and bypass (if dual feed) feeder circuit breakers to the OFF position.
7. Open the UPS front door.
8. Make sure that the battery breaker CB1 is in the OFF position.

9. Close the UPS front door.



WARNING

Power is still present inside each UPS cabinet until the upstream feeder circuit breaker is opened, and in case of a parallel system, the output is isolated or parallel units are shut down as well.

7.4.8 De-energizing the critical load

Initiate a UPS system Load Off by pressing the **Load Off** button in the **Controls**→**System Controls** screen. This button can be pressed to control the UPS output. The Load Off button de-energizes the critical load and shuts down the UPS system. The UPS system (including bypass) remains off until it is restarted.

1. Press **Load Off**.

The shutdown screen appears, providing a choice to proceed or abort the shutdown.

2. To shut down the UPS, press **YES**.

NOTE: All power to the critical load is lost when Load Off is selected. Only use this feature when you want to de-energize the critical load.

3. To cancel the shutdown, press **Abort**.

When Load Off is selected, the input, output, and bypass backfeed contactors are open, the battery breaker remains closed, and all the UPSs in the system are turned off.

To restart the UPS system, obey the procedure in *Section 7.4.1 Starting the UPS system in the double conversion mode* or *Section 7.5 Starting a single UPS*.



CAUTION

Do not attempt to restart the system after Load Off until you have identified and cleared the cause of the shutdown.

7.5 Starting a single UPS

Make sure that the load level does not exceed the single UPS capacity.

To start the UPS:

1. Close the UPS input feeder circuit breaker.
2. Close the UPS bypass input feeder circuit breaker.
3. Turn the mains switch RIS and the bypass switch BIS (if installed) in the ON position.
4. Open the UPS front door.
5. Turn the battery breaker CB1 in the ON position. Make sure that the breakers in the external battery cabinets are ON.
6. Make sure that there are no active alarms on display.
7. Close the UPS front door.
8. In the home screen, press **Controls**.
The System controls screen appears.
9. Press the UPS controls button.
In the UPS controls screen, the system status is shown as SHUTDOWN.

10. In the UPS controls screen, press the **GO online** button. Confirm **GO online**.

If Auto Bypass is enabled (factory default), the critical load is immediately supplied by the bypass source in the bypass mode, until the inverter turns on and the UPS transfers to the double conversion mode. The yellow status indicator on the UPS control panel indicates that the UPS is in the bypass mode. If auto bypass is not enabled, the UPS output remains off until the UPS system transfers to the double conversion mode.

11. Wait for the following messages to appear sequentially on the UPS status line:

STARTING
ONLINE

The UPS system is now operating in the double conversion mode and the green status indicator for normal operation is lit.

7.6 Shutting down a single UPS

A single UPS in the system can be shut down only if it is redundant. In practice, this means that a UPS is not allowed to be shut down if doing so would lead to an overload condition in the remaining UPSs in the system.

To shut down a single UPS:

1. In the home screen, press **Controls**.
The System controls screen is displayed.
2. In the System controls screen, press **UPS controls**.
3. In the UPS control screen, select **Shut down UPS**.

7.7 Enabling and disabling the battery charger

To turn the battery charger on or off, do the following procedure:

1. In the home screen, press **Controls**.
The System controls screen appears.
2. In the System controls screen, press **UPS controls**.
3. Press the **Turn on / Turn off** button.

7.8 Using the Remote Emergency Power-off switch

A UPS emergency power-off is initiated by the EPO pushbutton switch. In case of an emergency, you can use this switch to control the UPS output. The EPO switch de-energizes the critical load and powers down the UPS immediately without asking for verification. The UPS, including the static bypass switch, remains off until it is restarted.



CAUTION

When the EPO switch is activated, all power to the critical load is lost. Use this feature only in case of emergency.

NOTE: The following instructions are for the EPO switch supplied by Eaton Corporation. If you are using a customer-supplied EPO switch, it may not activate in the same way. For operating instructions, see the documentation provided with the switch.

To use EPO switch:

1. Press the EPO pushbutton switch.

The input, output, and bypass backfeed relays open, the battery breaker or disconnect is tripped, and the power module is turned off immediately, without asking for verification.

To restart the UPS after using the EPO pushbutton, reset the EPO switch and then follow the procedure in *Section 7.4.1 Starting the UPS system in the double conversion mode* or *Section 7.5 Starting a single UPS*.



WARNING

Do not attempt to restart the system after using the EPO switch until the conditions for safe start-up have been confirmed.

7.9 Turning the UPS from the double conversion mode to the maintenance bypass mode

Only trained personnel who are familiar with the behavior and functions of the UPS are allowed to operate the internal MBS.

To turn the UPS to maintenance bypass:

1. Follow the normal start position:

Figure 34. Normal positions of the switches

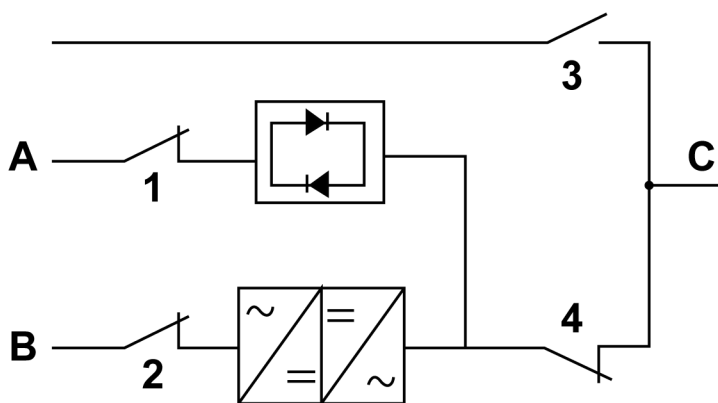

A	Bypass input	1	Bypass input switch (BIS)
B	Rectifier input	2	Rectifier input switch (RIS)
C	UPS Output	3	Maintenance bypass (MBP)
		4	Maintenance isolation switch (MIS)

2. Perform the transfer from the double conversion mode to the bypass mode as instructed in *Section 7.4.3 Transferring from the double conversion mode to the bypass mode*. Remember to verify the transfer before proceeding to the next step.
3. Remove the cover plate from front of the MBP and MIS.
4. Turn on the maintenance bypass (MBP). This connects the feed from bypass input to the UPS output.
5. Turn off the maintenance isolation switch (MIS). This disconnects the inverter and static bypass from the UPS output.
6. Perform the LOAD OFF procedure as described in *Section 7.4.8 De-energizing the critical load*.
7. Turn off the bypass input switch (BIS). This disconnects the static bypass from the bypass input.
8. Turn off the rectifier input switch (RIS). This de-energizes the rectifier.
9. Turn off the internal battery breaker (CB1) and all external battery breakers.

The UPS is now in the maintenance bypass mode:

Figure 35. Maintenance bypass mode

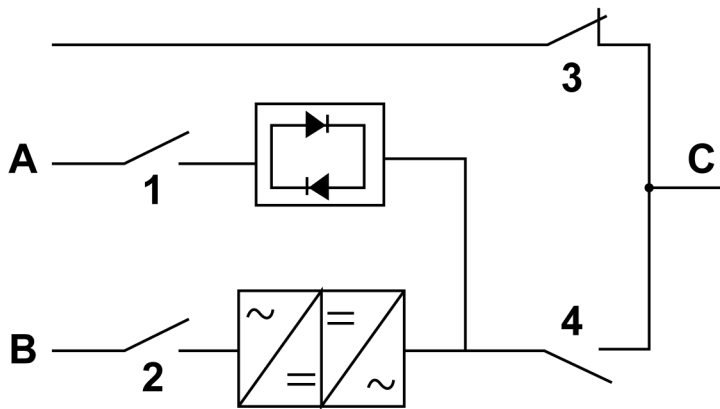

A	Bypass input	1	Bypass input switch (BIS)
B	Rectifier input	2	Rectifier input switch (RIS)
C	UPS Output	3	Maintenance bypass (MBP)
		4	Maintenance isolation switch (MIS)

7.10 Turning the UPS from the maintenance bypass mode to the double conversion mode

To turn the UPS back to the double conversion mode:

1. Follow the normal start position:

Figure 36. Maintenance bypass mode

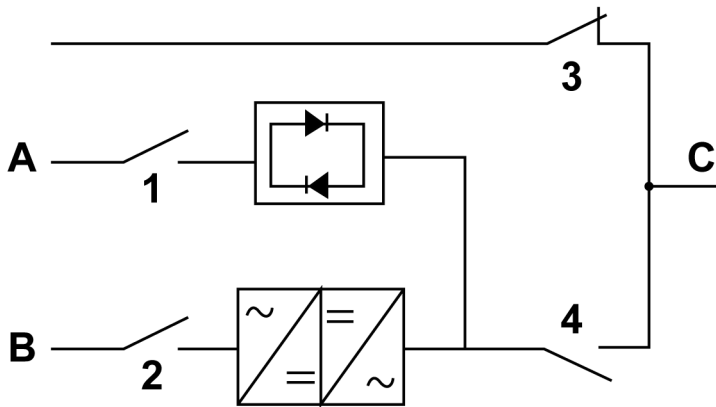

A	Bypass input	1	Bypass input switch (BIS)
B	Rectifier input	2	Rectifier input switch (RIS)
C	UPS Output	3	Maintenance bypass (MBP)
		4	Maintenance isolation switch (MIS)

2. Turn on the rectifier input switch (RIS). This energizes the rectifier.
3. Turn on the bypass input switch (BIS). This connects the static bypass to the bypass input.
4. Turn on the internal battery breaker (CB1) and all external battery breakers.
5. Perform the UPS start-up procedure (bypass mode) in *Section 7.4.2 Starting the UPS system in the bypass mode*.
6. Verify that there are no active alarms, and the UPS is on bypass mode.
7. Turn on the maintenance isolation switch (MIS). This connects the inverter and static bypass to the UPS output.
8. Turn off the maintenance bypass (MBP). This disconnects the feed from bypass input to the UPS output. The load is now supported by the static bypass.
9. Install the cover plate to front of the MBP and MIS.
10. Perform the transfer from the bypass mode to the double conversion mode as described in *Section 7.4.4 Transferring from the bypass mode to the double conversion mode*.

The UPS is now in the double conversion mode.

Figure 37. Normal positions of the switches

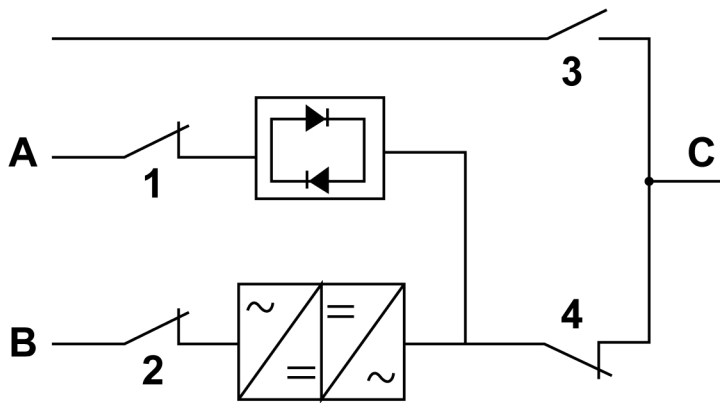

- | | | | |
|---|-----------------|---|------------------------------------|
| A | Bypass input | 1 | Bypass input switch (BIS) |
| B | Rectifier input | 2 | Rectifier input switch (RIS) |
| C | UPS Output | 3 | Maintenance bypass (MBP) |
| | | 4 | Maintenance isolation switch (MIS) |

8 UPS maintenance

8.1 UPS maintenance

The components inside the UPS cabinet are secured to a sturdy metal frame. All repairable parts and assemblies are located for easy removal with very little disassembly. This design allows authorized service personnel to perform routine maintenance and servicing quickly. Schedule periodic performance checks of your UPS system to keep it running properly. Regular routine checks of the operation and system parameters enable your system to function efficiently for many trouble-free years.

8.2 Important safety instructions

Remember that your UPS system is designed to supply power **EVEN WHEN IT IS DISCONNECTED FROM THE UTILITY POWER**. The UPS module interiors are unsafe until the DC power source is disconnected and the electrolytic capacitors are discharged.

After disconnecting the utility power and the DC power, authorized service personnel must wait at least 5 minutes for capacitor bleed-off before attempting internal access to the UPS module.



DANGER

LETHAL VOLTAGE. Do not operate the UPS system without the cabinet doors or protective panels secured. Do not make any assumptions about the electrical state of any cabinet in the UPS system.



WARNING

All service and maintenance work must be done only by service personnel qualified and authorized by Eaton.



CAUTION

A warning label, shown in Figure 38: *Warning label*, must be installed at the UPS input terminals and all the primary power isolators used to isolate the UPS unit if the UPS is connected to an IT earthed supply, or if the UPS input is connected through external isolators that, when opened, isolate the neutral. You can get these warning labels from your local service representative.

Figure 38. Warning label

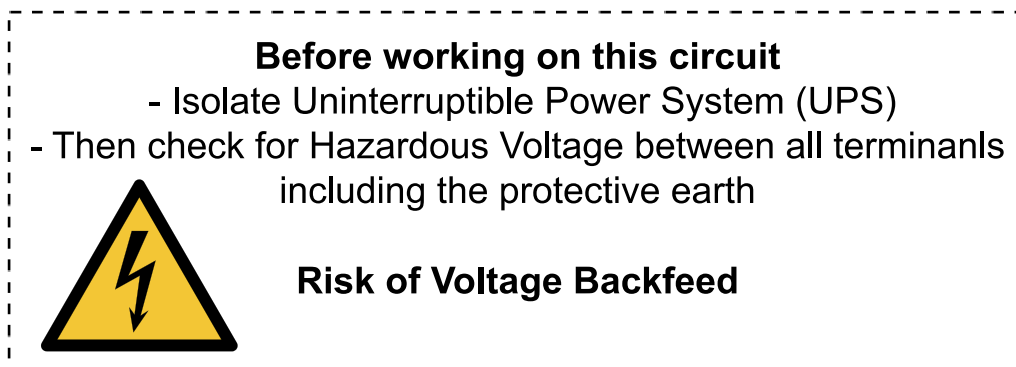

Since each battery string is an energy source in itself, opening the battery circuit breaker does not de-energize the voltage within the battery string.



DANGER

Do not attempt to access any internal area of the battery string. Voltages are always present in the battery strings. If you suspect that a battery string needs service, contact your service representative.

Obey these precautions when working on or around batteries:

- Remove watches, rings, or other metal objects.
- Use tools with insulated handles.
- Wear rubber gloves and boots.
- Do not lay tools or metal parts on top of batteries or battery cabinets.
- Before you connect or disconnect a terminal, first disconnect the charging source.
- Determine if the battery is inadvertently grounded. If it is, remove the source of the ground. Contact with any part of a grounded battery can result in an electrical shock. The likelihood of such a shock is reduced if such grounds are removed during installation and maintenance.
- When you replace batteries, use the same number of sealed, lead-acid batteries.
- Discard batteries according to your local codes for disposal requirements.

8.3 Preventive maintenance

The UPS system requires very little preventive maintenance. However, inspect the system periodically to verify that the units are operating normally and that the batteries are in good condition.

The majority of the service and maintenance work must be performed by service personnel qualified by Eaton. Only the actions described in *Sections 8.3.1 Daily maintenance* and *8.3.2 Monthly maintenance* and can be done by the user.

See the *Eaton 91PS/93PS UPS 8–10 kW Service Manual* for further information.

8.3.1 Daily maintenance

Do the following steps every day:

1. Examine the area surrounding the UPS system. Make sure that the area is not cluttered, allowing free access to the unit.
2. Examine that the air intakes (vents on the front doors) and exhaust opening (the back of the UPS cabinet sections) are not blocked.
3. Make sure that the operating environment is within the parameters specified in *Section 4.4.2 Installation considerations* and *Chapter 9.1 About technical data*.
4. Examine that the UPS is in the normal operation mode (the green status indicator for normal operation is illuminated). If the red alarm status indicator is illuminated or the green status indicator for normal operation is not illuminated, contact your service representative.

8.3.2 Monthly maintenance

Do the following steps once a month:

1. Examine the system parameters on the control panel (see *Section 7.2.4 Menu structure of the 91PS/93PS UPS*).
2. If the optional air filters are installed, examine them (located behind the front doors) and wash or replace them, if needed. Contact your service representative for replacement filters. To replace the filters:
 - a. Open the UPS front door.
 - b. Replace the filters.
 - c. Close the UPS front door.
3. Record the check results and any corrective actions in a service log.

8.3.3 Periodic maintenance

Inspect the UPS periodically to determine if components, wiring, and connections exhibit evidence of overheating. Pay particular attention to bolted connections. Bolted connections must be re-torqued periodically.

8.3.4 Annual maintenance



CAUTION

Only authorized personnel that are familiar with the maintenance and servicing of the UPS system are allowed to do annual preventive maintenance. Contact your service representative for more information about service offerings.

8.3.5 Battery maintenance



CAUTION

Only authorized personnel are allowed to do battery replacement and maintenance. Contact your service representative for battery maintenance.

8.4 Recycling the used UPS or batteries

Remove the battery bank before you discard the UPS or its battery cabinet. Obey the local requirements regarding battery recycling or disposal.



WARNING

Only authorized personnel are allowed to remove the batteries due to the risk caused by high energy and voltage.

Do not discard waste electrical or electronic equipment in the trash. For proper disposal, contact your local collecting/recycling/reuse or hazardous waste center and follow the local legislation.

The following symbols indicate a product requiring special handling:

Figure 39. WEEE symbol

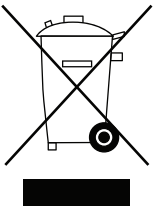

Figure 40. Recycling batteries symbol



When handling waste from electrical and electronic equipment, use proper local collecting centers that meet local legislation.



WARNING

HAZARDOUS MATERIALS.

Batteries may contain high voltages and caustic, toxic and flammable substances. If used improperly, batteries can injure or kill people and damage equipment.

Do not discard unwanted batteries or battery material in the public waste disposal system. Obey all the applicable local regulations regarding the storage, handling and disposal of batteries and battery materials.

8.5 Maintenance training

For more information about training and other services, contact your Eaton representative.

9 Technical data

9.1 About technical data

For a complete technical specification, contact your Eaton representative. Due to continuous product improvement programs, specifications are subject to change without notice.

NOTE:

For scalable (non-standard) models, refer to *Technical specification* .

9.2 Directives and standards

Table 23. Directives and standards

Safety	IEC 62040-1: Uninterruptible power systems (UPS) - Part 1: General and safety requirements for UPS IEC 62477-1: Safety requirements for power electronic converter systems and equipment -Part 1: General
EMC	IEC 62040-2: Uninterruptible power systems (UPS) - Part 2: Electromagnetic compatibility (EMC) requirements / Ed.2 • Emissions: category C2 • Immunity: category C3
Performance & tests	IEC 62040-3: Uninterruptible power systems (UPS) - Part 3: Method of specifying the performance and test requirements
Environmental	IEC62040-4: Uninterruptible Power Systems (UPS) - Part 4: Environmental Aspects - Requirements and Reporting IEC 62430: Environmentally conscious design for electrical and electronic products
RoHS	2011/65/EU on the restriction of the use of certain hazardous substances in electrical and electronic equipment
WEEE	2012/19/EU on waste electrical and electronic equipment (WEEE)
ECO Design Directive	2009/125/EC establishing a framework for the setting of eco-design requirements for energy-related products
Batteries	2006/66/EC on batteries and accumulators and waste batteries and accumulators
Packaging	94/62/EC on packaging and packaging waste

9.3 UPS system input

Table 24. UPS system input

Rated input voltage	220/380 V; 230/400 V; 240/415 V
Voltage tolerance, (Rectifier input)	230 V -15% / +20%
Voltage tolerance, (Bypass input)	230 V -15% / +10%
Rated input frequency	50 or 60 Hz
Frequency tolerance	40 to 72 Hz
Number of input phases (rectifier & bypass)	3 phases, N / 1 phase, N
Input power factor	0.99
Rated mains input current Maximum mains input current	See Tables 15: <i>Rated and maximum currents for rated power and voltage (93PS)</i> , 17: <i>Rated and maximum currents for rated power and voltage (91PS 1:1)</i> and 16: <i>Rated and maximum currents for rated power and voltage (91PS 3:1)</i>
Input current distortion at rated input current, iTHD	93PS 8 kW, 10 kW: resistive load <3%, non-linear load <5% 91PS 8 kW, 10 kW: resistive load <4%, non-linear load <6.5%
Rectifier ramp-up, rectifier start and load step	4 A/s (default), configurable. Min 1A/s
Backfeed protection	Yes, for rectifier and bypass lines

9.4 UPS system output

Table 25. UPS system output

Number of output phases	3 phases, N / 1 phase, N
Rated output voltage	220/380 V; 230/400 V; 240/415 V, configurable
Rated output frequency	50 or 60 Hz, user configurable
Total voltage harmonic distortion: 100 % linear load 100 % non-linear load	< 1.5% < 3.5%
Output frequency variation	+/- 0.1 Hz (free running)
Slew rate	1 Hz/s

Output current	See Tables 15: <i>Rated and maximum currents for rated power and voltage (93PS)</i> , 16: <i>Rated and maximum currents for rated power and voltage (91PS 3:1)</i> and 17: <i>Rated and maximum currents for rated power and voltage (91PS 1:1)</i>
Overload capability at ambient 40 °C (in the double conversion mode)	102 – 110 % rated power for 10 min 111 – 125 % rated power for 60 s 126 – 150 % rated power for 10 s > 150% rated power for 300 ms
Overload capability at ambient 40 °C (in the stored energy mode)	102 – 110 % rated power for 10 min 111 – 125 % rated power for 60 s 126 – 150 % rated power for 10 s > 150% rated power for 300 ms
Overload capability at ambient 40 °C (in the bypass mode)	Continuous ≤ 125% load Transient ≤ 1000% RMS current for 20 ms <i>NOTE: Bypass fuses may limit the overload capability.</i>
Load power factor (rated)	Nominal 1.0
Load power factor (permitted range)	From 0.8 lagging to 0.8 leading
Max ambient temperature without de-rating	40 °C

9.5 UPS environmental specifications

Table 26. UPS environmental specifications

Acoustic noise at 1 m	< 54 dbA in double conversion < 47 dbA in ESS
Ambient UPS storage and transportation temperature range	UPS: From -25 °C to +55 °C in the protective package Internal and external VRLA battery: From -25 °C to +25 °C in the protective package*
Ambient operating temperature range Recommended range*	From 0 °C to +40 °C From +20 °C to +25 °C
Relative humidity range Recommended range*	From 5 to 95%, no condensation allowed From 20 to 60%
Maximum rate of temperature change**	1.67 °C / 5 min
Maximum service altitude	1,000 m (3,300 ft) above sea level at rated maximum ambient temperature Maximum 2,000 m (6,600 ft) with 1% derating per each additional 100 m above 1,000 m.

Maximum storage time with internal batteries	6 months without discharge
Over voltage category	OVC II
Pollution degree	2
Protective class	Protective class I equipment

NOTE:

*) For a maximum lifetime for the UPS and batteries, keep the environment in the recommended range.

***) Limit based on ASHRAE 90.1-2013. Rapidly increasing temperature can cause condensation on colder surfaces.

Table 27. Electrical supply systems supported

Electrical supply system to which the UPS may be connected	TN/TT/IT
Electrical load system to which the UPS may be connected	TN/TT/IT
Electrical supply system supplied to the stored device	IT

9.6 Battery specification

Table 28. Battery specification

Battery type	VRLA, 12 VDC
Battery quantity	Default 32 blocks, 192 cells per battery string External battery 28...40 blocks, 168...240 cells per battery string <i>NOTE: Do not connect battery strings with different battery quantity and voltage in parallel.</i>
Battery voltage	384 V (32 blocks), 336 V (28 blocks), 480 V (40 blocks)
Recharge profile	Constant voltage, constant current charging (U-I characteristics), ABM or float charge
End of discharge voltage	1.67 VPC to 1.75 VPC, configurable or automatic (load adaptive)
Charge current	Configurable 0... 12.5 A
Battery start option	Yes

10 Warranty

10.1 General information about warranty

The product is warranted against defects in materials and workmanship for a period of twelve (12) months from its original date of purchase. The local office or distributor may grant a warranty period different to the above. Please refer to local terms of liability as defined in the supply contract.

The UPS manufacturer is not responsible for:

- Any costs resulting from a failure if the installation, commissioning, repair, alternation, or ambient conditions of the equipment do not fulfill the requirements specified in the documentation delivered with the unit and other relevant documentation.
- Equipment subjected to misuse, negligence or accident.
- Equipment comprised of materials provided or designs stipulated by the purchaser.

The warranty is only valid if the installation inspection and initial startup of the UPS unit is carried out by an authorized Eaton Field Service Engineer or by other qualified service personnel authorized by Eaton. Service and maintenance of the UPS shall also be performed only by an authorized Eaton Field Service Engineer or by other qualified service personnel authorized by Eaton. Otherwise the warranty will be voided.

If the product fails to meet its published specifications due to a defect in material and workmanship, covered by this warranty, the seller will repair or replace the warranted product. Such repair or replacement will be made by Eaton or by a service provider approved by Eaton. Repair or replacement during the warranty period does not extend the original warranty. Warranty does not cover taxes, which will be due in connection with replacement or repair of the product.

Batteries are warranted against failures in material and workmanship, not against the normal aging and reduction of ampere-hour capacity. The product storage environment has to meet manufacturer's specifications, failure to do this will cause the warranty to be voided.

Under no circumstances shall the manufacturer, its suppliers or subcontractors be liable for special, indirect, incidental or consequential damages, losses or penalties.

The technical data, information and specifications are valid at the time of printing. The UPS manufacturer reserves the right to modifications without prior notice.

10.2 Whom to contact in case of Warranty

In case of Warranty, or while unsure if the unit in question is covered by warranty, contact the respective sales organization where the unit was purchased. Have the following information available:

- Purchase order number and purchase order date
 - Installation date
- OR
- Serial number and part number of the unit (information available on the unit's label)

APPENDIX A: Recommended security hardening guidelines

The UPS has been designed with cybersecurity as an important consideration. Number of cybersecurity features are now offered in the product which, if implemented as per the recommendations in this section, would minimize the cybersecurity risk to the UPS. The “secure configuration” or “hardening” guidelines provide information to the users to securely deploy and maintain their product to adequately minimize the cybersecurity risks to their system.

Our company is committed to minimizing the cybersecurity risk in its products and deploys cybersecurity best practices and latest cybersecurity technologies in its products and solutions, making them more secure, reliable and competitive for our customers. Our company also offers Cybersecurity Best Practices whitepapers to its customers that can be referenced at www.eaton.com/cybersecurity.

Category	Description
Asset identification and inventory	<p>Keeping track of all the devices in the system is a prerequisite for effective management of cybersecurity of a system. Make sure that you maintain an inventory of all uniquely identify each component. To facilitate this, the UPS supports the following identifying information: manufacturer, type, serial number, f/w version number, and location. Users can extract device information at locations mentioned below:</p> <ul style="list-style-type: none"> • Product number, serial number and UPS name are listed on the Information screen • Firmware versions can be found on the About screen
Physical protection	<p>Industrial Control Protocols do not offer cryptographic protections at protocol level, at physical ports and at controller mode switches, leaving them exposed to cybersecurity risk. Physical security is an important layer of defense in such cases. The UPS is designed with the consideration that it would be deployed and operated in a physically secure location.</p> <ul style="list-style-type: none"> • Physical access to the communication lines should be restricted to prevent any attempts of wiretapping or sabotage. It is a best practice to use metal conduits for the communication lines running from one cabinet to another cabinet. • An attacker with unauthorized physical access to the device could cause serious disruption of the device functionality. A combination of physical access controls to the location should be used, such as locks, card readers, and/or guards. • The UPS supports the following physical access ports: RS232, USB and slots for communication cards. Access to them must be restricted. • Do not connect an unauthorized USB device, CD/DVD or SD card for any operation (for example, firmware upgrade, configuration change and boot application change). • Before connecting any portable device through USB, CD/DVD or SD card slot, scan the device for malwares and viruses.
Authorization and access control	<p>It is extremely important to securely configure the logical access mechanisms provided in the UPS to safeguard the device from unauthorized access. Our company recommends that the available access control mechanisms be used properly to ensure that access to the system is restricted to legitimate users only. And, such users are</p>

Category	Description
	<p>restricted to only the privilege levels necessary to complete their job roles/functions.</p> <ul style="list-style-type: none"> • Ensure that default credentials are changed upon first login. The UPS should not be commissioned for production with default credentials. It is a serious cybersecurity flaw as the default credentials are published in the manuals. • No password sharing - Make sure that each user gets their own password for that desired functionality instead of sharing the passwords. Security monitoring features of the UPS are created with the view of each user having their own unique password. Security controls will be weakened as soon as the users start sharing the password. • Restrict administrative privileges - Threat actors are increasingly focused on gaining control of legitimate credentials, especially those associated with highly privileged accounts. Limit privileges to only those needed for a user's duties. • Perform periodic account maintenance (remove unused accounts). • Change passwords and other system access credentials whenever there is a personnel change. <p>Access to service screen and configuration screen is access-controlled. Access to UPS features is restricted based on roles:</p> <ol style="list-style-type: none"> 1. Configuration screen can be accessed by the User role. 2. Service screen can be accessed only by the Service engineer role. <p>The following are the access levels in the UPS:</p> <ul style="list-style-type: none"> • Level 1: Control password for User • Level 2: Configure password for User • Level 3: Service password for an authorized Eaton Customer Service Engineer or qualified service personnel authorized by Eaton <p>Users are recommended to change default passwords on first use of the system. The default session timeout is 10 minutes.</p> <p>The UPS does not enforce any account policies. Customers need to enforce their account policies.</p>
Logging and event management	<p>Best practices:</p> <ul style="list-style-type: none"> • Our company recommends that all administrative and maintenance activities are logged. • Ensure that logs are backed up. Retain the backups for a minimum of 3 months or as per the organization's security policy. • Perform log review at a minimum every 15 days. <p>The UPS supports the following logging mechanisms:</p> <ul style="list-style-type: none"> • The UPS logs all active events, alarms and notices • Configuration changes made are logged (language change, modify UPS name, etc.)

Category	Description
Secure maintenance	<p>Best practices:</p> <p>Apply firmware updates and patches regularly.</p> <p>Due to increasing cyber attacks on industrial control systems, our company implements a comprehensive patch and update process for its products. Users are encouraged to maintain a consistent process to promptly monitor for fresh firmware updates, implement patching and updates as and when required or released.</p> <p>Our company will upgrade the UPS firmware from time to time. If any site needs to upgrade firmware, they can contact the service center for upgrade.</p> <p>Our company also has a robust vulnerability response process. In the event of any security vulnerability getting discovered in its products, our company patches the vulnerability and releases an information bulletin through its cybersecurity web site: http://eaton.com/cybersecurity.</p> <p>Conduct regular cybersecurity risk analyses of the organization/ system.</p> <p>Our company has worked with third-party security firms to perform system audits, both as part of a specific customer's deployment and within our company's own development cycle process. Our company can provide guidance and support to your organization's effort to perform regular cybersecurity audits or assessments.</p> <p>Plan for business continuity/cybersecurity disaster recovery.</p> <p>It is a cybersecurity best practice for organizations to plan for business continuity. Establish an OT business continuity plan, periodically review and, where possible, exercise the established continuity plans.</p> <p>Make sure offsite backups include:</p> <ul style="list-style-type: none"> • A backup of the most current configurations • Documentation of the most current user list

References:

1. Cybersecurity Considerations for Electrical Distribution Systems (WP152002EN). http://www.eaton.com/ecm/groups/public/@pub/@eaton/@corp/documents/content/pct_1603172.pdf
2. Cybersecurity Best Practices Checklist Reminder (WP910003EN). http://www.cooperindustries.com/content/dam/public/powersystems/resources/library/1100_EAS/WP910003EN.pdf
3. NIST SP 800-82 Rev 2, Guide to Industrial Control Systems (ICS) Security, May 2015. <https://ics-cert.us-cert.gov/Standards-and-References>
4. National Institute of Technology (NIST) Interagency "Guidelines on Firewalls and Firewall Policy, NIST Special Publication 800-41", October 2009. <http://nvlpubs.nist.gov/nistpubs/Legacy/SP/nistspecialpublication800-41r1.pdf>

Index

B

Basic system configurations	25
Battery system.....	25
Battery system installation	
Battery breaker wiring interface	50

C

Communication interfaces	57
Configuring relays	60
MiniSlot cards	58
Signal input monitoring	60

D

Double conversion mode.....	17
-----------------------------	----

G

Glossary	8
----------------	---

I

Installing interface connections	
Installing customer input signals interface.....	49
Introduction to Eaton 91PS/93PS 8–10 kW	
UPS	15
Introduction to Eaton UPS	
Options and accessories	24
UPS features	23
Introduction to UPS maintenance	77

L

Looking inside the UPS system.....	16
------------------------------------	----

M

Menu structure of the UPS	
User settings.....	67

O

Operating instructions	
Signing in.....	68

P

Periodic maintenance.....	79
---------------------------	----

R

Recommended security hardening guidelines ...	86
---	----

S

Safety	
Safety-related signs	6
Safety instructions	10
Audience	12
CE marking	12
Environment.....	13
For more information	14
Symbols on the UPS and accessories	13
User precautions	12
Site preparations	
Environmental and installation	
considerations	28
Environmental considerations.....	27
UPS system power wiring preparations	31
Software and connectivity features	
User interface.....	24
System control instructions	
De-energizing the critical load.....	71
Shutting down the UPS system and critical	
load	70
Starting the UPS system in the bypass	
mode	69
Starting the UPS system in the double	
conversion mode	68
Transferring from the bypass mode to the	
double conversion mode	70
Transferring from the double conversion mode	
to the Energy Saver System mode	70
Transferring from the Energy Saver System	
mode to the double conversion mode	70
Turning the UPS from the double conversion	
mode to the maintenance bypass mode.....	73

T

Technical data	
About technical data	81
Battery specification	84
Directives and standards.....	81
UPS environmental specifications.....	83
UPS system input	82
UPS system output.....	82
Turning the UPS from the maintenance	
bypass mode to the double conversion	
mode.....	74

U

Unpack and unload the UPS.....	38
UPS controls and indicators	
Control panel	64
Menu structure of the 91PS/93PS UPS	66
System events	65
UPS features	
Advanced Battery Management.....	23
Frequency Converter	24

Power Conditioner	23
Powerware Hot Sync	23
UPS installation plan and unpacking	
Create an installation plan	26
Installation checklist	26
Site preparations	27
To install the UPS	26
UPS maintenance	
Annual maintenance	79
Battery maintenance	79
Daily maintenance	78
Important safety instructions	77
Maintenance training	80
Monthly maintenance	79
Preventive maintenance	78
Recycling the used UPS or batteries	79
UPS operating instructions	
Enabling and disabling the battery charger	72
Introduction	64
Shutting down a single UPS	72
Starting a single UPS	71
Status indicators	65
Using the Remote Emergency Power-off switch	72
UPS operating modes	17
Bypass mode	21
Energy Saver System mode	19
Maintenance Bypass Switch	22
Normal operating modes	17
Stored energy and battery mode	20
UPS system installation	
91PS input system field configuration	44
Battery system installation	46
Battery trip wiring	47
Industrial Relay Card interface connections ...	50
Installing a remote EPO switch	48
Installing additional batteries and battery power cabling	47
Introduction	41
Steps to install the UPS	41
UPS system interface wiring preparation	55
User interface	
Power Management Software	24

W

Warranty	85
Wiring parallel 91PS/93PS UPS systems	
Control signals overview	53
Installing bypass control wiring	54
Power wiring overview	52



Powering Business Worldwide



Eaton Electric Oy
Riistakuja 1

FI-01740 Vantaa, Finland
www.eaton.eu

Copyright © 2023 Eaton Corporation plc.

All rights reserved. Unauthorized copying and lending are prohibited.